



200 Series Check Valves

Applications

Unidirectional flow applications such as CNG Dispensers, Fill Panels, Priority Panels, Compressors, Trailers and Service Stations. Suitable for CNG, Helium, Bio-Gas, Nitrogen, Air and other gases on request.



Check Valves 200 Series

Materials

Item	Part	Material
1	Body	304 Stainless steel
2	End Cap	304 Stainless steel
3	Poppet body	316 Stainless steel
4	Poppet seal	Delrin
5	Poppet O-ring	Nitrile
6	End Cap O-rings	Nitrile
7	Poppet spring	302 Stainless steel

Features & Benefits

Stainless steel two-piece, serviceable check valve that sets the standard in flow rates.

Precision manufactured from certified bar stock, ensuring endurance and reliability in any application.

Easy to install service kits are readily available.

Product Information

NPT & SAE female thread are standard configuration.

NPT threads conform to ASME B1.20.1 and SAE threads conform to SAE J1926-1.

All products are manufactured under ISO 9001 accredited standards.

Springs with different cracking pressure available upon request, minimum order quantities may apply.

Designed for unidirectional flow.

Video servicing instructions available online at www.OasisNGV.com/resources

PED 97/23/CE approved.



200 Series Check Valves

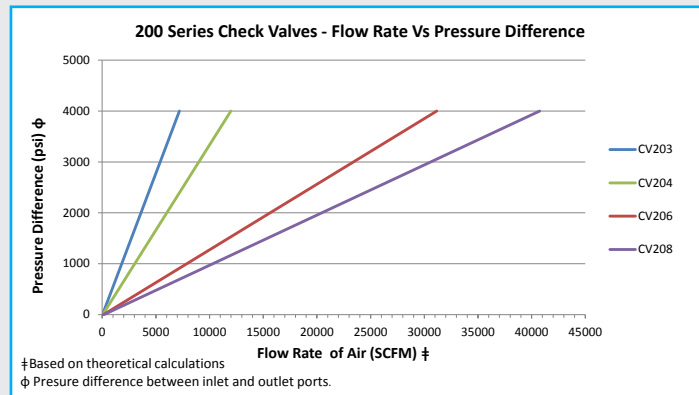

NPT Product Specification

Part Code	Mass lb (kg)	Min. Crack Pressure psi (bar) *	Max. Operating Pressure psi (bar) ^	Min. Temp. °F (°C)	Max. Temp. °F (°C)	Cv	Service Kit Ordering Number
CV203-4NDSN	0.7 (0.3)	2 (0.14)	6000 (410)	-40 (-40)	185 (85)	3	CV203-SKDSN
CV204-4NDSN	1.1 (0.5)	2 (0.14)	6000 (410)	-40 (-40)	185 (85)	5	CV204-SKDSN
CV206-4NDAN	3 (1.4)	0.5 (0.03)	6000 (410)	-40 (-40)	185 (85)	13	CV206-SKDAN
CV208-4NDAN	3.7 (1.7)	0.5 (0.03)	6000 (410)	-40 (-40)	185 (85)	17	CV208-SKDAN

SAE Product Specification

Part Code	Mass lb (kg)	Min. Crack Pressure psi (bar) *	Max. Operating Pressure psi (bar) ^	Min. Temp. °F (°C)	Max. Temp. °F (°C)	Cv	Service Kit Ordering Number
CV204-4SDSN	1.1 (0.5)	2 (0.14)	6000 (410)	-40 (-40)	185 (85)	5	CV204-SKDSN-S
CV206-4SDAN	3 (1.4)	0.5 (0.03)	6000 (410)	-40 (-40)	185 (85)	13	CV206-SKDAN-S
CV208-4SDAN	3.7 (1.7)	0.5 (0.03)	6000 (410)	-40 (-40)	185 (85)	17	CV208-SKDAN-S

* Minimum upstream pressure at which the valve will operate.

^ Maximum pressure at which the product can continuously operate at.



200 Series Check Valves

Dimensions:

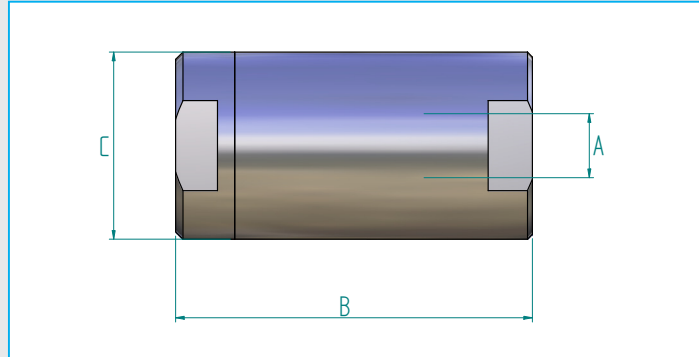

NPT Dimensions: Imperial (mm)

Part Code	Thread Type	Bore	Length	Diameter
		A	B	C
CV203-4NDSN	3/8" NPT	0.35 (9)	2.28 (58)	1.25 (31.5)
CV204-4NDSN	1/2" NPT	0.47 (12)	2.87 (73)	1.5 (38.2)
CV206-4NDAN	3/4" NPT	0.78 (20)	3.98 (100)	2.15 (54.7)
CV208-4NDAN	1" NPT	1 (25)	4.29 (109)	2.35 (59.8)

SAE Dimensions: Imperial (mm)

Part Code	Thread Type	Bore	Length	Diameter
		A	B	C
CV204-4SDSN	3/4-16 SAE FEMALE	0.47 (12)	2.87 (73)	1.5 (38.2)
CV206-4SDAN	1 1/16-12 SAE FEMALE	0.78 (20)	3.98 (100)	2.15 (54.7)
CV208-4SDAN	1 5/16-12 SAE FEMALE	1 (25)	4.29 (109)	2.35 (59.8)