

Gaugeable Tube Fittings and Adapter Fittings



- Available in tube sizes from 1/16 to 2 in. and 2 to 50 mm
- Consistent gaugeability upon initial make-up
- Easy to disconnect and retighten
- Wide variety of materials and configurations

Contents

Straight Configurations

Unions

- Union 8
- Reducing Union 9
- Bulkhead Union 10
- Bulkhead Reducing Union 11
- AN Union 11
- AN Bulkhead Union 11
- Tube Socket Weld Union 11



Male Connectors

- NPT Thread 12
- ISO Tapered Thread (RT) 14
- ISO Parallel Thread (RS) 15
- ISO Parallel Thread (RP) 16
- Bulkhead Male NPT 17
- SAE/MS Straight Thread 17
- O-seal SAE/MS Straight Thread 18
- O-seal NPT Thread 18
- Pipe Weld 19



Female Connectors

- NPT Thread 20
- ISO Tapered Thread (RT) 21
- ISO Parallel Gauge Thread (RG) 22
- Bulkhead NPT 22



Reducers

- Reducer 23
- Long Reducer 24
- Bulkhead Reducer 24



Port Connectors

- Port Connector 25
- Reducing Port Connector 25

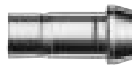

Caps and Plugs



Vent Protectors



Flanges

- ANSI 27
- DIN 27
- JIS—Ordinary Type 27



Elbows—90° Configurations

Unions

- Union 28
- Tube Socket Weld 28



Male Connectors

- Male NPT Thread 29
- Male ISO Tapered Thread 30
- Positionable—
SAE/MS Straight Thread 30
- Positionable—
ISO Parallel Thread 31
- Pipe Weld 31

Female Connectors

- NPT Thread 32

Elbows—45° Configurations

Male Connectors

- NPT Thread 32
- Positionable—
SAE/MS Straight Thread 32



Tees

Unions

- Union 33
- Reducing Union 33



Male Connectors

- Branch, NPT Thread 34
- Run, NPT Thread 35
- Positionable Run,
SAE/MS Straight Thread 35
- Positionable Run,
ISO Parallel Thread 35
- Positionable Branch,
SAE/MS Straight Thread 36
- Positionable Branch,
ISO Parallel Thread 36

Female Connectors

- Run, NPT Thread 37
- Branch, NPT Thread 37

Union Cross 38



Tube Adapters

Male Adapters

- Tube Adapter Information 38
- NPT Thread 39
- ISO Tapered Thread (RT) 40
- ISO Parallel Thread (RS) 40
- ISO Parallel Thread (RP) 41
- SAE/MS Straight Thread 41
- O-seal SAE/MS Straight Thread 41
- AN Thread 42
- Pipe Weld Adapter 42



Female Adapters

- NPT Thread 43
- ISO Tapered Thread (RT) 43
- ISO Parallel Thread (RP) 44
- ISO Parallel Gauge Thread (RG) 44
- AN Thread 44

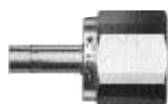

Chromatograph Fittings

See the *Gaugeable Chromatograph and Column End Fittings* catalog.



Replacement Parts

Nuts

- Female 45
- Knurled Female 45
- Male 45



Ferrules

- Nut-Ferrule Set and Package ... 46
- Ferrule Set and Ferrule-Pak™ Package 46
- Front 47
- Back 47



ISO Parallel Gaskets

- Steel Gasket ISO Parallel Thread (RS) 48
- Copper Gasket ISO Parallel Thread (RP) 48
- Copper Gasket ISO Parallel Gauge Fittings (RG) 48



O-rings

- For ISO Parallel Threads 49
- For SAE/MS Straight Threads ... 49
- For O-seal Straight Threads. 49
- For O-seal Pipe Threads 49

Tools and Accessories

Gap Inspection Gauges 50



Bulkhead Retainer 51



Preswaging Tool 52



Insert for Swagelok Vinyl or Tygon® Tubing 52



Hydraulic Swaging Units ... 53



Installation Instructions ... 54

Features

Two-Ferrule Mechanical Grip Design

As the nut is turned, the back ferrule:

- axially advances the front ferrule
- radially applies an effective tube grip.

The front ferrule creates a seal:

- against the fitting body
- on the tubing OD.

The two ferrules separate sealing and tube retaining functions, each ferrule optimized for its function.

Installation

- Easy to install using hand tools
- No torque is transmitted to tubing during installation
- Swagelok gap inspection gauge assures sufficient pull-up upon initial installation

An installation training seminar is available.

Contact your independent Swagelok sales and service representative for details.

Installation instructions are available (see page 54).



Advanced Geometry Back Ferrule Design

is standard on all 1/4 to 1/2 in. and 6 to 12 mm Swagelok stainless steel tube fittings.

To help installers make more consistent, leak-tight tube connections, Swagelok stainless steel tube fittings, in sizes from 1/4 to 1/2 in. and 6 to 12 mm, include a patented advanced-geometry back ferrule. This back ferrule design provides:

- Excellent gas-tight sealing and tube-gripping action
- Reduced potential for improper pull-up
- Consistent remakes
- Excellent vibration fatigue resistance and tube support
- Full compatibility with original Swagelok stainless steel tube fittings and front ferrules of identical sizes
- Easy 1 1/4-turn installation
- Gaugeability on initial installation using Swagelok gap inspection gauges

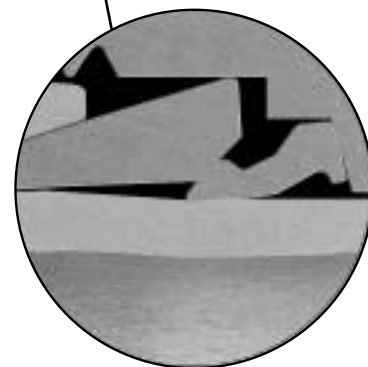

For additional information, see the *Swagelok Advanced Tube Fitting Technical Report*.

Ordering Information

Add the material designator as a prefix to the basic ordering number. Example: **SS-400-1-4**

Material	Designators
316 stainless steel	SS
Alloy 20	C20
Alloy 400/R-405	M
Alloy 600	INC
Alloy C-276	HC
Aluminum	A
Brass	B
Carbon steel	S ^①
Nylon	NY
PTFE	T
SAF 2507™	2507
Titanium	TI

① Includes stainless steel back ferrule.

- SAE/MS positionable fittings are available in carbon steel and stainless steel only.
- Minimum order quantities may apply to certain materials and configurations.
- For SAF 2507 super duplex fittings, see the *Swagelok Gaugeable SAF 2507™ Super Duplex Tube Fittings* catalog.
- For PFA tube fittings, see the *Swagelok PFA Tube Fittings and PFA Tubing* catalog.
- Heavy-wall fittings are available only in 316 stainless steel. The basic ordering numbers for these fittings include the material designator. See the *Swagelok High-Pressure Fittings* catalog.
- Contact your independent Swagelok sales and service representative for information about additional sizes and special alloys.

Dimensions

- Dimensions, in inches (millimeters), are for reference only and are subject to change.
- Dimensions are shown with Swagelok nuts finger-tight. For Swagelok nut dimensions, see page 45.
- CAD templates are available on www.swagelok.com.

Materials Standards

Material	Bar Stock ^①	Forgings ^②
316 stainless steel	ASTM A276 ASME SA479	ASTM A182 ASME SA182
Alloy 20	ASTM B473	ASTM B462
Alloy 400/R-405	ASTM B164 ASME SB164	ASTM B564 ASME SB564
Alloy 600	ASTM B166 ASME SB166	ASTM B564 ASME SB564
Alloy C-276	ASTM B574	ASTM B564
Aluminum	ASTM B211	ASTM B247
Brass	ASTM B16 ASTM B453	ASTM B283
Carbon steel	ASTM A108	—
Nylon	ASTM D4066	—
PTFE	ASTM D1710	ASTM D3294
SAF 2507	ASTM A479	ASTM A182
Titanium	ASTM B348	ASTM B381

① Includes straight configurations.

② Includes all elbows, crosses, and tees.

O-rings

O-seal fittings include a 70 durometer Buna O-ring. Other straight thread fittings with O-rings include a 90 durometer fluorocarbon FKM O-ring. Other O-ring materials are available upon request. O-rings are coated with a thin film of silicone-based lubricant. Removal of factory applied lubricants may alter performance.

Plating and Coating

For improved performance, fitting components receive additional processing. Fitting bodies that are subjected to further processing (plating and coating) are shown below:

Fitting Material	Body Process
Aluminum	Anodized, hydrocarbon film
Alloy 400/R-405, Alloy 20 Alloy C-276, Alloy 600	Hydrocarbon film
Carbon steel (except weld bodies)	Zinc plating
Carbon steel (welded bodies)	Hydrocarbon film Chemical conversion coating
Titanium	Anodized
Brass, nylon, 316 stainless steel, and PTFE	Not applicable

- Over 1 in. and over 25 mm stainless steel fittings use stainless steel ferrules with PFA coating. Applications above 450°F (232°C) **require** silver-plated front ferrules and uncoated back ferrules. To order fittings with silver-plated ferrules, add **-BM** as a suffix to the basic ordering number.
- All carbon steel Swagelok tube fittings are supplied with 316 stainless steel back ferrules.

Pressure Ratings and Tubing Information

Swagelok Tube Fitting Pressure Ratings

Swagelok tube fitting ends are rated to the working pressure of tubing as listed in the *Swagelok Tubing Data* catalog. Careful selection of high-quality tubing is important when installing safe, leak-tight systems.

Pipe End (NPT and ISO 7) Pressure Ratings

Pressure ratings for fittings that have both tube fitting and pipe thread ends are determined by the end connection with the lowest pressure rating. The **Pipe End (NPT and ISO 7) Pressure Ratings** chart lists pressure ratings for male and female **tapered pipe thread ends**. For female and male pipe threads to have the same pressure rating in the same nominal pipe size, the female thread would require a heavier wall, resulting in a fitting too large and bulky to be practical.

Stress values based on ASME B31.3 Code for Process Piping

Material	Allowable Stress Value		Design Factor	Ultimate Tensile Strength	
	psi	bar		psi	bar
316 SS	20 000	1378	3.75:1	75 000	5170
Brass	10 000	689	4:1	40 000	2760
Steel	20 000	1378	3:1	60 000	4140

Calculations based on ASME B31.3 Code for Process Piping

NPT/ISO Pipe Size in.	316 SS and Carbon Steel				Brass			
	Male		Female		Male		Female	
	psig	bar	psig	bar	psig	bar	psig	bar
1/16	11 000	760	6700	460	5500	380	3300	230
1/8	10 000	690	6500	440	5000	340	3200	220
1/4	8000	550	6600	450	4000	270	3300	220
3/8	7800	540	5300	360	3900	270	2600	180
1/2	7700	530	4900	330	3800	260	2400	160
3/4	7300	500	4600	320	3600	250	2300	160
1	5300	370	4400	300	2600	180	2200	150
1 1/4	6000	410	5000	350	3000	200	2500	170
1 1/2	5000	340	4600	310	2500	170	2300	150
2	3900	270	3900	270	1900	130	1900	130

To determine working pressure ratings in accordance with ASME B31.1 Power Piping for 316 stainless steel, multiply psig by 0.94; for carbon steel, multiply psig by 0.75. Brass ratings remain the same. To determine working kPa, multiply psig by 6.89.

SAE/MS Pressure Ratings

Pressure ratings are from SAE J1926/3.

SAE/MS Thread Size	316 SS and Carbon Steel			
	(Nonpositionable)		(Positionable)	
	psig	bar	psig	bar
5/16-24	4568	315	4568	315
7/16-20				
1/2-20			3626	250
9/16-18				
3/4-16	3626	250	2900	200
7/8-14				
1 1/16-12			2900	200
1 3/16-12				
1 5/16-12	2320	160		
1 5/8-12				
1 7/8-12	1813	125	1450	100
2 1/2-12				

O-Seal Pressure Ratings

Stainless steel and carbon steel O-seal fittings up to 1 in. and 25 mm are rated to 3000 psig (206 bar).

Note: Some fittings with AN, O-seal, and SAE/MS ends may have lower ratings. For more information, contact your independent Swagelok sales and service representative.

Thread Specifications

Thread Type	Reference Specification
NPT	ASME B1.20.1, SAE AS71051
ISO/BSP (parallel) (Based on DIN 3852) (Swagelok RP and RS fittings)	ISO 228, JIS B 0202
ISO/BSP (tapered) (Based on DIN 3852) (Swagelok RT fittings)	ISO 7, BS 21 JIS B 0203
ISO/BSP (gauge) (Based on EN 837-1 and 837-3) (Swagelok RG fittings)	ISO 228
Unified (SAE)	ASME B1.1

Pipe Thread Sealants

A thread sealant should always be used when assembling tapered threads. SWAK® anaerobic pipe thread sealant and PTFE tape are available through your independent Swagelok sales and service representative. For more information, see the *Tools and Accessories* catalog in your Swagelok product binder.

1 1/4 in. / 28 mm and Larger Swagelok Tube Fittings

A **hydraulic swaging unit must be used** when installing 1 1/4, 1 1/2, 2 in., 28, 30, 32, 38, and 50 mm Swagelok tube fittings. The unit is designed to swage the ferrules on the tubing prior to the final assembly into a fitting. See page 53 for complete information.

Identifying Metric Swagelok Tube Fittings

All metric tube fittings have a stepped shoulder on the body hex. Shaped fittings, such as elbows, crosses, and tees, are stamped *MM* for metric tubing, and have no step on forging.

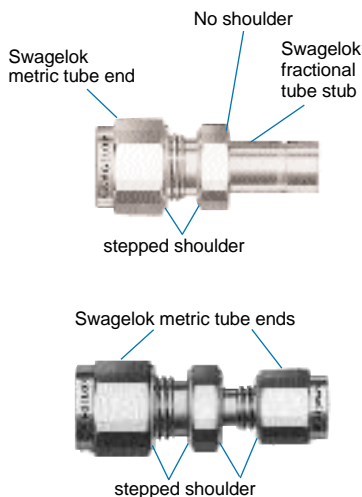

Cleaning

Fitting components are cleaned to remove machine oil, grease, and loose particles. For more information, see Swagelok Specification SC-10.

Interchangeability

Other tube fitting manufacturers often claim that their components are interchangeable with Swagelok tube fitting components.

We believe that interchanging and intermixing tube fitting components of different designs, made by different manufacturers, can result in leaks and tube slippage in a percentage of cases. We also believe this practice can be dangerous in critical applications.

Leak-tight seals that will withstand high pressure, vibration, vacuum, and temperature changes depend upon close tolerances and consistent, exacting quality control in conjunction with good design principles.

The full value we build into Swagelok tube fittings is lost when components from other manufacturers are interchanged or intermixed with ours. We believe that **any** manufacturer's fitting performs best when only that manufacturer's components are used in its fittings.

We do not believe that a tube fitting made up by interchanging and intermixing components of other manufacturers with genuine Swagelok tube fitting components will perform to the high standards of an all-Swagelok tube fitting.

Safety Precautions

- Do not bleed system by loosening fitting nut or fitting plug.
- Do not make up and tighten fittings when system is pressurized.
- Make sure that the tubing rests firmly on the shoulder of the tube fitting body before tightening the nut.
- Use Swagelok gap inspection gauge to ensure sufficient pull-up upon initial installation.
- Never allow problems to go unreported.
- Always use proper thread sealants on tapered pipe threads.
- Do not mix materials or fitting components from various manufacturers—tubing, ferrules, nuts, and fitting bodies.
- Never turn fitting body. Instead, hold fitting body and turn nut.
- Avoid unnecessary disassembly of unused fittings.
- Use only long reducers in female Swagelok ports.
- Additional tubing considerations:
 1. Metal tubing material should be softer than fitting material. For example, stainless steel tubing should not be used with brass fittings.
 2. When tubing and fittings are made of the same material, tubing must be fully annealed.
 3. Always use an insert with extremely soft or pliable plastic tubing.
 4. Extremes of wall thickness should always be checked against fitting manufacturer's suggested minimum and maximum wall thickness limitations.
 5. Surface finish is very important to proper sealing. Tubing with any kind of depression, scratch, raised portion, or other surface defect will be difficult to seal, particularly in gas service.
 6. Tubing that is oval and will not easily fit through fitting nuts, ferrules, and bodies should never be forced into the fitting.

Union

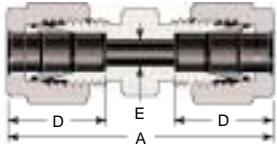

Tube OD	Basic Ordering Number	Dimensions		
		A	D	E
<i>Dimensions, in.</i>				
1/16	-100-6	0.99	0.34	0.05
1/8	-200-6	1.40	0.50	0.09
3/16	-300-6	1.47	0.54	0.12
1/4	-400-6	1.61	0.60	0.19
5/16	-500-6	1.69	0.64	0.25
3/8	-600-6	1.77	0.66	0.28
1/2	-810-6	2.02	0.90	0.41
5/8	-1010-6	2.05	0.96	0.50
3/4	-1210-6	2.11	0.96	0.62
7/8	-1410-6	2.17	1.02	0.72
1	-1610-6	2.55	1.23	0.88
1 1/4	-2000-6	3.63	1.62	1.09
1 1/2	-2400-6	4.25	1.97	1.34
2	-3200-6	5.88	2.66	1.81
<i>Dimensions, mm</i>				
2	-2M0-6	35.6	12.9	1.7
3	-3M0-6	35.3	12.9	2.4
4	-4M0-6	37.3	13.7	2.4
6	-6M0-6	41.0	15.3	4.8
8	-8M0-6	43.2	16.2	6.4
10	-10M0-6	46.2	17.2	7.9
12	-12M0-6	51.2	22.8	9.5
14	-14M0-6	52.0	24.4	11.1
15	-15M0-6	52.0	24.4	11.9
16	-16M0-6	52.0	24.4	12.7
18	-18M0-6	53.5	24.4	15.1
20	-20M0-6	55.0	26.0	15.9
22	-22M0-6	55.0	26.0	18.3
25	-25M0-6	65.0	31.3	21.8
28	-28M0-6	85.0	36.6	21.8
30	-30M0-6	92.7	39.6	26.2
32	-32M0-6	97.3	42.0	28.6
38	-38M0-6	113.6	49.4	33.7
50	-50M0-6	145.8	65.0	45.2

Reducing Union

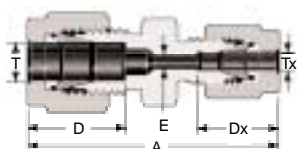

T Tube OD	Tx Tube OD	Basic Ordering Number	Dimensions			
			A	D	Dx	E
<i>Dimensions, in.</i>						
1/8	1/16	-200-6-1	1.22	0.50	0.34	0.05
3/16	1/16	-300-6-1	1.27	0.54	0.34	0.05
	1/8	-300-6-2	1.44		0.50	0.09
1/4	1/16	-400-6-1	1.35	0.60	0.34	0.05
	1/8	-400-6-2	1.52		0.50	0.09
	3/16	-400-6-3	1.55		0.54	0.12
5/16	1/8	-500-6-2	1.56	0.64	0.50	0.09
	1/4	-500-6-4	1.66		0.60	0.19
3/8	1/16	-600-6-1	1.44	0.66	0.34	0.05
	1/8	-600-6-2	1.61		0.50	0.09
	1/4	-600-6-4	1.70		0.60	0.19
	5/16	-600-6-5	1.74		0.64	0.25
1/2	1/8	-810-6-2	1.78	0.90	0.50	0.09
	1/4	-810-6-4	1.85		0.60	0.19
	3/8	-810-6-6	1.91		0.66	0.28
5/8	3/8	-1010-6-6	1.94	0.96	0.66	0.28
	1/2	-1010-6-8	2.05		0.90	0.41
3/4	1/4	-1210-6-4	1.94	0.96	0.60	0.19
	3/8	-1210-6-6	2.00		0.66	0.28
	1/2	-1210-6-8	2.11		0.90	0.41
	5/8	-1210-6-10	2.11		0.96	0.50
1	1/2	-1610-6-8	2.38	1.23	0.90	0.41
	3/4	-1610-6-12			0.96	0.62
<i>Dimensions, mm</i>						
3	2	-3M0-6-2M	35.3	12.9	12.9	1.7
6	2	-6M0-6-2M	38.6	15.3	12.9	1.7
	3	-6M0-6-3M	38.6		12.9	2.4
	4	-6M0-6-4M	39.4		13.7	2.4
8	6	-8M0-6-6M	42.3	16.2	15.3	4.8
10	6	-10M0-6-6M	44.5	17.2	15.3	4.8
	8	-10M0-6-8M	45.1		16.2	6.4
12	6	-12M0-6-6M	47.0	22.8	15.3	4.8
	8	-12M0-6-8M	47.8		16.2	6.4
	10	-12M0-6-10M	48.7		17.2	7.9
16	10	-16M0-6-10M	45.9	24.4	17.2	7.9
	12	-16M0-6-12M	52.0		22.8	9.5
18	12	-18M0-6-12M	53.5	24.4	22.8	9.5
25	18	-25M0-6-18M	61.0	31.3	24.4	15.1
	20	-25M0-6-20M	62.3		26.0	15.9
30	18	-30M0-6-18M	75.4	39.6	24.4	15.1
	20	-30M0-6-20M	75.4		26.0	15.9
	25	-30M0-6-25M	80.1		31.3	21.8
32	18	-32M0-6-18M	77.8	42.0	24.4	15.1
	20	-32M0-6-20M	77.8		26.0	15.9
	25	-32M0-6-25M	82.3		31.3	21.8
38	20	-38M0-6-20M	87.5	49.4	26.0	15.9
	25	-38M0-6-25M	92.0		31.3	21.8
	30	-38M0-6-30M	104.6		39.6	26.2

Reducing Union

Metric to Fractional

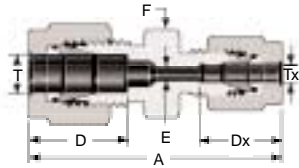

T Tube OD mm	Tx Tube OD in.	Basic Ordering Number	Dimensions				
			A	D	Dx	E	F Flat
<i>Dimensions, mm</i>							
2	1/8 1/4	-2M0-6-2 -2M0-6-4	35.2 38.6	12.9	12.8 15.3	1.7	12 14
3	1/8	-3M0-6-2	35.2	12.9	12.8	2.4	12
4	1/8 1/4	-4M0-6-2 -4M0-6-4	36.5 39.4	13.7	12.8 15.3	2.4	12 14
6	1/8 1/4 5/16	-6M0-6-2 -6M0-6-4 -6M0-6-5	38.5 41.0 42.3	15.3	12.8 15.3 16.2	2.4 4.8 4.8	14
8	1/4 3/8	-8M0-6-4 -8M0-6-6	42.3 44.3	16.2	15.3 16.9	4.8 6.4	15 16
10	1/8 1/4 5/16 3/8	-10M0-6-2 -10M0-6-4 -10M0-6-5 -10M0-6-6	41.8 44.5 45.1 45.9	17.2	12.8 15.3 16.2 16.9	2.4 4.8 6.4 7.1	18
12	5/16 3/8 1/2	-12M0-6-5 -12M0-6-6 -12M0-6-8	47.8 48.4 51.2	22.8	16.2 16.9 22.8	6.4 7.1 9.5	22
15	1/2	-15M0-6-8	52.0	24.4	22.8	10.3	24
16	5/8	-16M0-6-10	52.0	24.4	24.4	12.7	24
18	3/4	-18M0-6-12	53.5	24.4	24.4	15.1	27
20	1/2 1	-20M0-6-8 -20M0-6-16	55.0 62.8	26.0	22.8 31.3	10.3 15.9	30 35
25	1	-25M0-6-16	65.0	31.3	31.3	21.8	35

Bulkhead Union

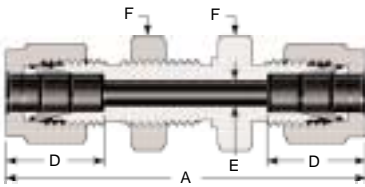

Tube OD	Basic Ordering Number	Dimensions					
		A	D	E	F Flat	Panel Hole Size	Max Panel Thickness
<i>Dimensions, in.</i>							
1/16	-100-61	1.24	0.34	0.05	5/16	13/64	0.12 ^①
1/8	-200-61	2.02	0.50	0.09	1/2	21/64	0.50
3/16	-300-61	2.11	0.54	0.12	9/16	25/64	0.50
1/4	-400-61	2.27	0.60	0.19	5/8	29/64	0.40
5/16	-500-61	2.39	0.64	0.25	11/16	33/64	0.44
3/8	-600-61	2.45	0.66	0.28	3/4	37/64	0.44
1/2	-810-61	2.80	0.90	0.41	15/16	49/64	0.50
5/8	-1010-61	2.86	0.96	0.50	1 1/16	57/64	0.50
3/4	-1210-61	3.11	0.96	0.62	1 3/16	1 1/64	0.66
1	-1610-61	3.77	1.23	0.88	1 5/8	1 21/64	0.75
1 1/4	-2000-61	4.85	1.62	1.09	1 7/8	1 41/64	0.75
1 1/2	-2400-61	5.48	1.97	1.34	2 1/4	1 61/64	0.75
2	-3200-61	7.10	2.66	1.81	2 3/4	2 41/64	0.75
<i>Dimensions, mm</i>							
3	-3M0-61	51.3	12.9	2.4	14	8.3	12.7
4	-4M0-61	53.6	13.7	2.4	14	9.9	12.7
6	-6M0-61	57.7	15.3	4.8	16	11.5	10.2
8	-8M0-61	61.0	16.2	6.4	18	13.1	11.2
10	-10M0-61	63.7	17.2	7.9	22	16.3	11.2
12	-12M0-61	71.0	22.8	9.5	24	19.5	12.7
14	-14M0-61	72.5	24.4	11.1	27	22.5	12.7
15	-15M0-61	72.5	24.4	11.9	27	22.8	12.7
16	-16M0-61	72.5	24.4	12.7	27	22.8	12.7
18	-18M0-61	78.9	24.4	15.1	30	26.0	16.8
20	-20M0-61	84.5	26.0	15.9	35	29.0	19.0
30	-30M0-61	123.7	39.6	26.2	50	40.5	19.0
32	-32M0-61	128.3	42.0	28.6	50	42.5	19.0
38	-38M0-61	144.6	49.4	33.7	60	50.5	19.0

① Minimum panel thickness is 0.06 in.

Bulkhead Reducing Union

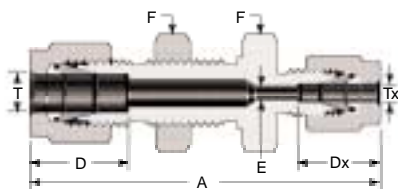

T Tube OD	Tx Tube OD	Basic Ordering Number	Dimensions						
			A	D	Dx	E	F Flat	Panel Hole Size	Max Panel Thickness
<i>Dimensions, in.</i>									
1/4	1/8	-400-61-2	2.17	0.60	0.50	0.09	5/8	29/64	0.40
3/8	1/4	-600-61-4	2.39	0.66	0.60	0.19	3/4	37/64	0.44
1/2	1/4	-810-61-4	2.63	0.90	0.60	0.19	15/16	49/64	0.50

AN Union

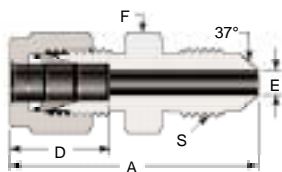

Tube OD	AN Tube Flare Size	Basic Ordering Number	Dimensions				
			A	D	E ^①	F Flat	S
<i>Dimensions, in.</i>							
1/16	1/8	-100-6-2AN	1.07	0.34	0.05	7/16	5/16-24UNJF-3
1/8	1/8	-200-6-2AN	1.27	0.50	0.06	7/16	5/16-24UNJF-3
	1/4	-200-6-4AN	1.38		0.09	1/2	7/16-20UNJF-3
1/4	1/4	-400-6-4AN	1.48	0.60	0.17	1/2	7/16-20UNJF-3
5/16	5/16	-500-6-5AN	1.51	0.64	0.23	9/16	1/2-20UNJF-3
3/8	1/4	-600-6-4AN	1.56	0.66	0.17	5/8	7/16-20UNJF-3
	3/8	-600-6-6AN			0.28		9/16-18UNJF-3
1/2	1/2	-810-6-8AN	1.81	0.90	0.39	13/16	3/4-16UNJF-3
3/4	3/4	-1210-6-12AN	2.10	0.96	0.61	1 1/8	1 1/16-12UNJ-3
1	1	-1610-6-16AN	2.42	1.23	0.84	1 3/8	1 5/16-12UNJ-3

① The E dimension is the minimum nominal opening. These fittings may have a larger opening at the pipe/straight thread end.

AN Bulkhead Union

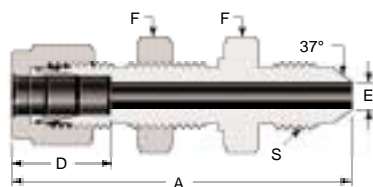

Tube OD	AN Tube Flare Size	Basic Ordering Number	Dimensions						
			A	D	E	F Flat	S	Panel Hole Size	Max Panel Thickness
<i>Dimensions, in.</i>									
1/4	1/4	-400-61-4AN	2.12	0.60	0.17	5/8	7/16-20UNJF-3	29/64	0.40
3/8	3/8	-600-61-6AN	2.25	0.66	0.28	3/4	9/16-18UNJF-3	37/64	0.44
1/2	1/2	-810-61-8AN	2.59	0.90	0.39	15/16	3/4-16UNJF-3	49/64	0.50
3/4	3/4	-1210-61-12AN	3.11	0.96	0.61	1 3/16	1 1/16-12UNJ-3	1 1/4	0.66
1	1	-1610-61-16AN	3.64	1.23	0.84	1 5/8	1 5/16-12UNJ-3	1 21/64	0.75

Tube Socket Weld Union

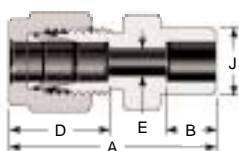

Tube OD	Socket Weld Size	Basic Ordering Number	Dimensions				
			A	B	D	E	J
<i>Dimensions, in.</i>							
1/8	1/8	-200-6-2W	1.14	0.10	0.50	0.09	0.29
1/4	1/4	-400-6-4W	1.32	0.28	0.60	0.19	0.48
3/8	3/8	-600-6-6W	1.48	0.31	0.66	0.28	0.60
1/2	1/2	-810-6-8W	1.62	0.38	0.90	0.41	0.73
3/4	3/4	-1210-6-12W	1.71	0.44	0.96	0.62	1.04
1		-1610-6-16W	2.07	0.62	1.23	0.88	1.36

Male Connectors

Male NPT Thread

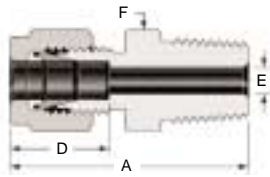

Tube OD	NPT Male Pipe Size	Basic Ordering Number	Dimensions			
			A	D	E ^①	F Flat
<i>Dimensions, in.</i>						
1/16	1/16	-100-1-1	0.94	0.34	0.05	5/16
	1/8	-100-1-2	1.03			7/16
	1/4	-100-1-4	1.22			9/16
1/8	1/16	-200-1-1	1.17	0.50	0.09	7/16
	1/8	-200-1-2	1.20			7/16
	1/4	-200-1-4	1.40			9/16
	3/8	-200-1-6	1.41			11/16
	1/2	-200-1-8	1.66			7/8
3/16	1/8	-300-1-2	1.23	0.54	0.12	7/16
	1/4	-300-1-4	1.43			9/16
1/4	1/16	-400-1-1	1.29	0.60	0.12	1/2
	1/8	-400-1-2	1.29		0.19	1/2
	1/4	-400-1-4	1.49		0.19	9/16
	3/8	-400-1-6	1.51		0.19	11/16
	1/2	-400-1-8	1.76		0.19	7/8
	3/4	-400-1-12	1.82		0.19	1 1/16
5/16	1/8	-500-1-2	1.34	0.64	0.19	9/16
	1/4	-500-1-4	1.52		0.25	9/16
	3/8	-500-1-6	1.54		0.25	11/16
3/8	1/8	-600-1-2	1.39	0.66	0.19	5/8
	1/4	-600-1-4	1.57		0.28	5/8
	3/8	-600-1-6	1.57		0.28	11/16
	1/2	-600-1-8	1.82		0.28	7/8
	3/4	-600-1-12	1.88		0.28	1 1/16
1/2	1/8	-810-1-2	1.53	0.90	0.19	13/16
	1/4	-810-1-4	1.71		0.28	13/16
	3/8	-810-1-6	1.71		0.38	13/16
	1/2	-810-1-8	1.93		0.41	7/8
	3/4	-810-1-12	1.99		0.41	1 1/16
	1	-810-1-16	2.25		0.41	1 3/8
5/8	3/8	-1010-1-6	1.74	0.96	0.38	15/16
	1/2	-1010-1-8	1.93		0.47	15/16
	3/4	-1010-1-12	1.99		0.50	1 1/16
3/4	1/2	-1210-1-8	1.99	0.96	0.47	1 1/16
	3/4	-1210-1-12	1.99		0.62	1 1/16
	1	-1210-1-16	2.25		0.62	1 3/8
7/8	3/4	-1410-1-12	1.99	1.02	0.62	1 3/16
	1	-1410-1-16	2.25		0.72	1 3/8
1	1/2	-1610-1-8	2.26	1.23	0.47	1 3/8
	3/4	-1610-1-12	2.26		0.62	
	1	-1610-1-16	2.45		0.88	
1 1/4	1	-2000-1-16	3.04	1.62	0.88	1 3/4
	1 1/4	-2000-1-20	3.04		1.09	
1 1/2	1 1/2	-2400-1-24	3.50	1.97	1.34	2 1/8
2	2	-3200-1-32	4.47	2.66	1.81	2 3/4

① The E dimension is the minimum nominal opening. These fittings may have a larger opening at the pipe/straight thread end.



Bored-Through Fittings for Thermocouples, Dip Tubes, and Heat Exchanger Tees

Swagelok bored-through male connectors accommodate thermocouples or dip tubes. Most male connectors are available as a bored-through fitting. Male connectors whose pipe thread end is small relative to the tube fitting end, like a -600-1-2 or an -8M0-1-2RT, cannot be bored through.

Swagelok bored-through reducers and standard Swagelok tees can be used to create a heat exchanger tee.

To order bored-through fittings, add **BT** as a suffix to the ordering number.

Example: SS-400-1-4BT

NOTE: Bored-through fittings may have a reduced pressure rating. Contact your independent Swagelok representative for details.

Male Connectors

Male NPT Thread

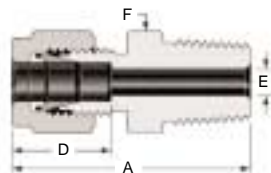

Tube OD	NPT Male Pipe Size, in.	Basic Ordering Number	Dimensions				
			A	D	E ^①	F Flat	
<i>Dimensions, mm</i>							
2	1/8	-2M0-1-2	30.5	12.9	1.7	12	
3	1/8	-3M0-1-2	30.5	12.9	2.4	12	
	1/4	-3M0-1-4	35.6			14	
4	1/8	-4M0-1-2	31.2	13.7	2.4	12	
	1/4	-4M0-1-4	36.3			14	
6	1/8	-6M0-1-2	32.8	15.3	4.8	14	
	1/4	-6M0-1-4	37.9			14	
	3/8	-6M0-1-6	38.4			18	
	1/2	-6M0-1-8	44.7			22	
8	1/8	-8M0-1-2	34.2	16.2	4.8	15	
	1/4	-8M0-1-4	38.7			15	
	3/8	-8M0-1-6	39.3			18	
	1/2	-8M0-1-8	45.6			22	
10	1/8	-10M0-1-2	36.3	17.2	4.8	18	
	1/4	-10M0-1-4	40.9			18	
	3/8	-10M0-1-6	40.9			18	
	1/2	-10M0-1-8	46.5			22	
	3/4	-10M0-1-12	48.0			27	
12	1/8	-12M0-1-2	38.8	22.8	4.8	22	
	1/4	-12M0-1-4	43.4			22	
	3/8	-12M0-1-6	43.4			22	
	1/2	-12M0-1-8	49.0			22	
	3/4	-12M0-1-12	50.5			27	
14	1/4	-14M0-1-4	44.1	24.4	7.1	24	
	3/8	-14M0-1-6	44.1				
	1/2	-14M0-1-8	49.0				
15	1/2	-15M0-1-8	49.0	24.4	11.9	24	
16	3/8	-16M0-1-6	44.1	24.4	9.5	24	
	1/2	-16M0-1-8	49.0			24	
	3/4	-16M0-1-12	50.5			27	
18	1/2	-18M0-1-8	50.5	24.4	11.9	27	
	3/4	-18M0-1-12					15.1
20	1/2	-20M0-1-8	52.3	26.0	11.9	30	
	3/4	-20M0-1-12					15.9
22	3/4	-22M0-1-12	52.3	26.0	15.9	30	
	1	-22M0-1-16				18.3	35
25	1/2	-25M0-1-8	57.5	31.3	11.9	35	
	3/4	-25M0-1-12					15.9
	1	-25M0-1-16					21.8
28	1	-28M0-1-16	72.4	36.6	21.8	41	
	1 1/4	-28M0-1-20				73.1	46
30	1 1/4	-30M0-1-20	77.2	39.6	26.2	46	
32	1 1/4	-32M0-1-20	79.6	42.0	28.6	46	
38	1 1/2	-38M0-1-24	91.6	49.4	33.7	55	

① The E dimension is the minimum nominal opening. These fittings may have a larger opening at the pipe/straight thread end.

Male Connectors

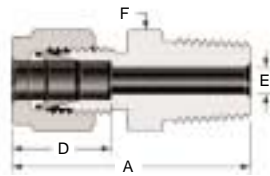

See page 7 for thread specifications.

Male ISO Tapered Thread (RT)

Tube OD	ISO Male Pipe Size, in.	Basic Ordering Number	Dimensions			
			A	D	E ^①	F Flat
Dimensions, in.						
1/8	1/8 1/4	-200-1-2RT -200-1-4RT	1.20 1.40	0.50	0.09	7/16 9/16
1/4	1/8 1/4 3/8 1/2	-400-1-2RT -400-1-4RT -400-1-6RT -400-1-8RT	1.29 1.49 1.51 1.76	0.60	0.19	1/2 9/16 11/16 7/8
5/16	1/8 1/4	-500-1-2RT -500-1-4RT	1.34 1.52	0.64	0.19 0.25	9/16
3/8	1/8 1/4 3/8 1/2	-600-1-2RT -600-1-4RT -600-1-6RT -600-1-8RT	1.39 1.57 1.57 1.82	0.66	0.19 0.28 0.28 0.28	5/8 5/8 11/16 7/8
1/2	1/4 3/8 1/2 3/4	-810-1-4RT -810-1-6RT -810-1-8RT -810-1-12RT	1.71 1.71 1.93 1.99	0.90	0.28 0.38 0.41 0.41	13/16 13/16 7/8 1 1/16
3/4	3/4	-1210-1-12RT	1.99	0.96	0.62	1 1/16
1	1	-1610-1-16RT	2.45	1.23	0.88	1 3/8
Dimensions, mm						
2	1/8	-2M0-1-2RT	30.5	12.9	1.7	12
3	1/8 1/4	-3M0-1-2RT -3M0-1-4RT	30.5 35.6	12.9	2.4	12 14
4	1/8 1/4	-4M0-1-2RT -4M0-1-4RT	31.2 36.3	13.7	2.4	12 14
6	1/8 1/4 3/8 1/2	-6M0-1-2RT -6M0-1-4RT -6M0-1-6RT -6M0-1-8RT	32.8 37.9 38.4 44.7	15.3	4.8	14 14 18 22
8	1/8 1/4 3/8 1/2	-8M0-1-2RT -8M0-1-4RT -8M0-1-6RT -8M0-1-8RT	34.2 38.7 39.2 45.6	16.2	4.8 6.4 6.4 6.4	15 15 18 22
10	1/8 1/4 3/8 1/2	-10M0-1-2RT -10M0-1-4RT -10M0-1-6RT -10M0-1-8RT	36.3 40.9 40.9 46.5	17.2	4.8 7.1 7.9 7.9	18 18 18 22
12	1/4 3/8 1/2 3/4	-12M0-1-4RT -12M0-1-6RT -12M0-1-8RT -12M0-1-12RT	43.4 43.4 49.0 50.5	22.8	7.1 9.5 9.5 9.5	22 22 22 27
15	1/2	-15M0-1-8RT	49.0	24.4	11.9	24
16	1/4 3/8 1/2 3/4	-16M0-1-4RT -16M0-1-6RT -16M0-1-8RT -16M0-1-12RT	44.1 44.1 49.0 50.5	24.4	7.1 9.5 11.9 12.7	24 24 24 27
18	1/2 3/4	-18M0-1-8RT -18M0-1-12RT	50.5	24.4	11.9 15.1	27
20	1/2 3/4	-20M0-1-8RT -20M0-1-12RT	52.3	26.0	11.9 15.9	30
22	3/4 1	-22M0-1-12RT -22M0-1-16RT	52.3 57.1	26.0	15.9 18.3	30 35
25	3/4 1	-25M0-1-12RT -25M0-1-16RT	57.5 62.3	31.3	15.9 21.8	35
28	1 1 1/4	-28M0-1-16RT -28M0-1-20RT	72.4 73.1	36.6	21.8	41 46
30	1 1/4	-30M0-1-20RT	77.2	39.6	26.2	46
32	1 1/4	-32M0-1-20RT	79.6	42.0	28.6	46
38	1 1/2	-38M0-1-24RT	91.6	49.4	33.7	55

① The E dimension is the minimum nominal opening. These fittings may have a larger opening at the pipe/straight thread end.

Male Connectors

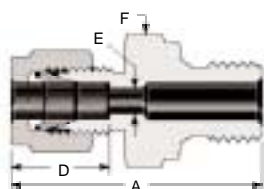

See page 7 for thread specifications.
ISO parallel gaskets are available.
See page 48.

Male ISO Parallel Thread (RS)

Tube OD	ISO Male Pipe Size, in.	Basic Ordering Number	Dimensions			
			A	D	E ^①	F Flat
Dimensions, in.						
1/8	1/8	-200-1-2RS	1.31	0.50	0.09	9/16
	1/4	-200-1-4RS	1.50			3/4
	3/8	-200-1-6RS	1.53			7/8
1/4	1/8	-400-1-2RS	1.40	0.60	0.16	9/16
	1/4	-400-1-4RS	1.59			3/4
	3/8	-400-1-6RS	1.62			7/8
	1/2	-400-1-8RS	1.70			1 1/16
3/8	1/4	-600-1-4RS	1.65	0.66	0.23	3/4
	3/8	-600-1-6RS	1.68			7/8
	1/2	-600-1-8RS	1.76			1 1/16
1/2	1/4	-810-1-4RS	1.76	0.90	0.23	13/16
	3/8	-810-1-6RS	1.79			7/8
	1/2	-810-1-8RS	1.87			1 1/16
3/4	1/2	-1210-1-8RS	1.92	0.96	0.47	1 1/16
	3/4	-1210-1-12RS	2.05			1 5/16
1	1/2	-1610-1-8RS	2.19	1.23	0.47	1 3/8
	1	-1610-1-16RS	2.35			1 5/8
Dimensions, mm						
2	1/8	-2M0-1-2RS	33.3	12.9	1.7	14
3	1/8	-3M0-1-2RS	33.3	12.9	2.4	14
	1/4	-3M0-1-4RS	38.1			19
4	1/8	-4M0-1-2RS	34.0	13.7	2.4	14
6	1/8	-6M0-1-2RS	35.6	15.3	4.0	14
	1/4	-6M0-1-4RS	40.4			19
	3/8	-6M0-1-6RS	41.1			22
	1/2	-6M0-1-8RS	43.2			27
8	1/8	-8M0-1-2RS	36.6	16.2	4.0	15
	1/4	-8M0-1-4RS	41.4			19
	3/8	-8M0-1-6RS	42.2			22
	1/2	-8M0-1-8RS	44.2			27
10	1/4	-10M0-1-4RS	42.2	17.2	5.9	19
	3/8	-10M0-1-6RS	42.9			22
	1/2	-10M0-1-8RS	45.0			27
12	1/4	-12M0-1-4RS	44.5	22.8	5.9	22
	3/8	-12M0-1-6RS	45.5			22
	1/2	-12M0-1-8RS	47.5			27
	3/4	-12M0-1-12RS	52.1			35
16	3/8	-16M0-1-6RS	45.5	24.4	7.9	24
	1/2	-16M0-1-8RS	47.5			27
18	1/2	-18M0-1-8RS	48.8	24.4	11.9	27
	3/4	-18M0-1-12RS	52.1			35
20	1/2	-20M0-1-8RS	50.5	26.0	11.9	30
	3/4	-20M0-1-12RS	52.6			35
22	3/4	-22M0-1-12RS	52.6	26.0	15.9	35
	1	-22M0-1-16RS	54.9			41
25	3/4	-25M0-1-12RS	57.7	31.3	15.9	35
	1	-25M0-1-16RS	59.7			41
28	1	-28M0-1-16RS	69.9	36.6	19.8	41
	1 1/4	-28M0-1-20RS	72.9			50
30	1 1/4	-30M0-1-20RS	76.7	39.6	25.0	50
32	1 1/4	-32M0-1-20RS	79.2	42.0	25.0	50
38	1 1/2	-38M0-1-24RS	90.9	49.4	31.8	55

① The E dimension is the minimum nominal opening. These fittings may have a larger opening at the pipe/straight thread end.

Male Connectors

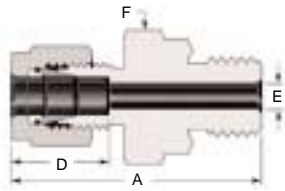

See page 7 for thread specifications.
ISO parallel gaskets are available.
See page 48.

Male ISO Parallel Thread (RP)

Tube OD	ISO Male Pipe Size, in.	Basic Ordering Number	Dimensions			
			A	D	E ^①	F Flat
Dimensions, in.						
1/8	1/8 1/4	-200-1-2RP -200-1-4RP	1.31 1.50	0.50	0.09	9/16 3/4
1/4	1/8 1/4	-400-1-2RP -400-1-4RP	1.40 1.59	0.60	0.16 0.19	9/16 3/4
1/2	1/2	-810-1-8RP	1.87	0.90	0.41	1 1/16
Dimensions, mm						
3	1/8 1/4	-3M0-1-2RP -3M0-1-4RP	33.3 38.1	12.9	2.4	14 19
4	1/8	-4M0-1-2RP	34.0	13.7	2.4	14
6	1/8	-6M0-1-2RP	35.6	15.3	4.0	14
	1/4	-6M0-1-4RP	40.4		4.8	19
	3/8	-6M0-1-6RP	41.2		4.8	22
	1/2	-6M0-1-8RP	43.2		4.8	27
8	1/8	-8M0-1-2RP	36.5	16.2	4.0	15
	1/4	-8M0-1-4RP	41.3		5.9	19
	3/8	-8M0-1-6RP	41.9		6.4	22
	1/2	-8M0-1-8RP	44.1		6.4	27
10	1/4	-10M0-1-4RP	42.2	17.2	5.9	19
	3/8	-10M0-1-6RP	42.9		7.9	22
	1/2	-10M0-1-8RP	45.0		7.9	27
12	1/4	-12M0-1-4RP	45.4	22.8	5.9	22
	3/8	-12M0-1-6RP	45.4		7.9	22
	1/2	-12M0-1-8RP	47.5		9.5	27
	3/4	-12M0-1-12RP	52.3		9.5	35
15	1/2	-15M0-1-8RP	47.5	24.4	11.9	27
16	3/8	-16M0-1-6RP	45.4	24.4	7.9	24
	1/2	-16M0-1-8RP	47.5		11.9	27
18	1/2	-18M0-1-8RP	49.0	24.4	11.9	27
	3/4	-18M0-1-12RP	52.3		15.1	35
20	1/2	-20M0-1-8RP	50.5	26.0	11.9	30
	3/4	-20M0-1-12RP	52.5		15.9	35
22	3/4	-22M0-1-12RP	52.8	26.0	15.9	35
	1	-22M0-1-16RP	54.5		18.3	41
25	3/4	-25M0-1-12RP	57.8	31.3	15.9	35
	1	-25M0-1-16RP	59.8		19.8	41
28	1	-28M0-1-16RP	69.8	36.6	19.8	41
	1 1/4	-28M0-1-20RP	72.9		21.8	50
30	1 1/4	-30M0-1-20RP	76.8	39.6	26.2	50
32	1 1/4	-32M0-1-20RP	79.2	42.0	28.6	50
38	1 1/2	-38M0-1-24RP	92.1	49.4	31.8	55

① The E dimension is the minimum nominal opening. These fittings may have a larger opening at the pipe/straight thread end.

Male Connectors

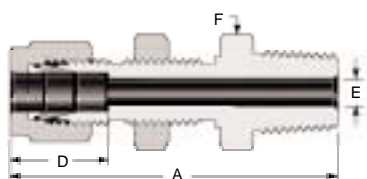

① The E dimension is the minimum nominal opening. These fittings may have a larger opening at the pipe/straight thread end.

Bulkhead Male NPT Connector

Tube OD	NPT Male Pipe Size, in.	Basic Ordering Number	Dimensions					
			A	D	E ^①	F Flat	Panel Hole Size	Max Panel Thickness
<i>Dimensions, in.</i>								
1/8	1/8	-200-11-2	1.83	0.50	0.09	1/2	21/64	0.50
1/4	1/8	-400-11-2	1.95	0.60	0.19	5/8	29/64	0.40
	1/4	-400-11-4	2.13					
3/8	1/4	-600-11-4	2.26	0.66	0.28	3/4	37/64	0.44
	3/8	-600-11-6	2.26					
	1/2	-600-11-8	2.51					
1/2	3/8	-810-11-6	2.49	0.90	0.38 0.41	15/16	49/64	0.50
	1/2	-810-11-8	2.71					
3/4	3/4	-1210-11-12	3.00	0.96	0.62	1 3/16	1 1/64	0.66
1	1	-1610-11-16	3.67	1.23	0.88	1 5/8	1 21/64	0.75
<i>Dimensions, mm</i>								
6	1/4	-6M0-11-4	53.6	15.3	4.8	16	11.5	10.2
12	1/2	-12M0-11-8	68.8	22.8	9.5	24	19.5	12.7

Male SAE/MS Straight Thread

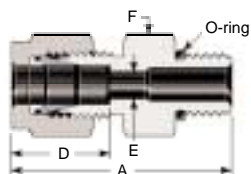

Adapts to SAE J1926 straight thread boss and SAE J1926/1 boss.

① The E dimension is the minimum nominal opening. These fittings may have a larger opening at the pipe/straight thread end.

Tube OD	SAE/MS Thread Size	Basic Ordering Number	Dimensions			
			A	D	E ^①	F Flat
<i>Dimensions, in.</i>						
1/8	5/16-24	-200-1-2ST	1.18	0.50	0.09	7/16
	7/16-20	-200-1-4ST	1.24			9/16
	9/16-18	-200-1-6ST	1.31			11/16
1/4	7/16-20	-400-1-4ST	1.34	0.60	0.19	9/16
	9/16-18	-400-1-6ST	1.40			11/16
	3/4-16	-400-1-8ST	1.48			7/8
	7/8-14	-400-1-10ST	1.60			1
5/16	1/2-20	-500-1-5ST	1.37	0.64	0.25	5/8
3/8	7/16-20	-600-1-4ST	1.40	0.66	0.18 0.28 0.28 0.28	5/8
	9/16-18	-600-1-6ST	1.46			11/16
	3/4-16	-600-1-8ST	1.54			7/8
	7/8-14	-600-1-10ST	1.66			1
1/2	9/16-18	-810-1-6ST	1.54	0.90	0.28 0.41 0.41 0.41	13/16
	3/4-16	-810-1-8ST	1.65			7/8
	7/8-14	-810-1-10ST	1.77			1
	1 1/16-12	-810-1-12ST	1.93			1 1/4
5/8	3/4-16	-1010-1-8ST	1.65	0.96	0.42 0.50	15/16
	7/8-14	-1010-1-10ST	1.78			1
3/4	3/4-16	-1210-1-8ST	1.81	0.96	0.42 0.62	1 1/16
	1 1/16-12	-1210-1-12ST	1.93			1 1/4
7/8	1 3/16-12	-1410-1-14ST	1.93	1.02	0.72	1 3/8
	1	1 1/16-12	-1610-1-12ST	2.10	1.23	0.66 0.88
1 5/16-12		-1610-1-16ST	2.14	1 1/2		
1 1/4	1 5/8-12	-2000-1-20ST	2.69	1.62	1.09	1 7/8
1 1/2	1 7/8-12	-2400-1-24ST	3.06	1.97	1.34	2 1/8
2	2 1/2-12	-3200-1-32ST	4.00	2.66	1.81	2 3/4

Male Connectors

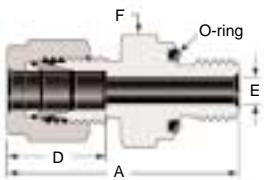

① The E dimension is the minimum nominal opening. These fittings may have a larger opening at the pipe/straight thread end.

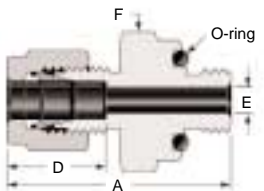

① The E dimension is the minimum nominal opening. These fittings may have a larger opening at the pipe/straight thread end.

Fig. 1

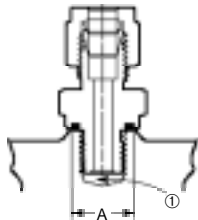

Fig. 2

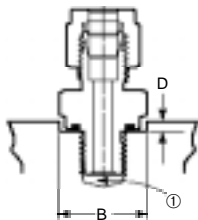
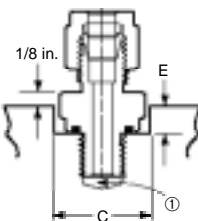

Fig. 3



① Allow clearance for full thread.

O-seal Fitting (Male SAE/MS Straight Thread)

Tube OD	SAE/MS Male Thread Size	Basic Ordering Number	Dimensions			
			A	D	E ^①	F Flat
<i>Dimensions, in.</i>						
1/16	5/16-24	-100-1-OR	1.05	0.34	0.05	9/16
1/8	5/16-24	-200-1-OR	1.29	0.50	0.09	9/16
3/16	3/8-24	-300-1-OR	1.35	0.54	0.12	5/8
1/4	7/16-20	-400-1-OR	1.51	0.60	0.19	3/4
5/16	1/2-20	-500-1-OR	1.60	0.64	0.25	7/8
3/8	9/16-18	-600-1-OR	1.67	0.66	0.28	15/16
1/2	3/4-16	-810-1-OR	1.81	0.90	0.41	1 1/8
3/4	1 1/16-12	-1210-1-OR	2.06	0.96	0.62	1 1/2
1	1 5/16-12	-1610-1-OR	2.29	1.23	0.88	1 3/4

O-seal Fitting (Male NPT Thread)

Tube OD	NPT Male Pipe Size	Basic Ordering Number	Dimensions			
			A	D	E ^①	F Flat
<i>Dimensions, in.</i>						
1/8	1/8	-200-1-2-OR	1.29	0.50	0.09	3/4
1/4	1/8	-400-1-2-OR	1.38	0.60	0.19	3/4
	1/4	-400-1-4-OR	1.51			15/16
3/8	1/4	-600-1-4-OR	1.57	0.66	0.28	15/16
	3/8	-600-1-6-OR	1.63			1 1/8
	1/2	-600-1-8-OR	1.85			1 5/16
1/2	1/2	-810-1-8-OR	1.96	0.90	0.41	1 5/16

Mounting Dimensions for O-Seal Connectors

For a raised surface, see Fig. 1. The minimum diameter allows metal-to-metal contact outside of the O-ring sealing diameter to prevent O-ring extrusion.

For a recessed hole that allows the round shoulder of the O-seal fitting into the recess, see Fig. 2.

For a recessed hole that allows the hex of the O-seal fitting into the recess, see Fig. 3.

SAE/MS Thread Size	NPT Male Pipe Size	A Min Dia	B Min Dia	C Min Dia	D Max Depth	E Max Depth
<i>Dimensions, in.</i>						
5/16-24	—	0.50	0.59	0.66	0.09	0.16
5/16-24	—	0.50	0.59	0.66	0.09	0.22
—	1/8	0.69	0.78	0.88	0.16	0.28
3/8-24	—	0.56	0.66	0.75	0.09	0.22
7/16-20	—	0.69	0.78	0.88	0.16	0.28
—	1/8	0.69	0.78	0.88	0.16	0.28
—	1/4	0.87	0.97	1.09	0.16	0.31
1/2-20	—	0.75	0.91	1.03	0.16	0.31
9/16-18	—	0.81	0.97	1.09	0.16	0.31
—	1/4	0.87	0.97	1.09	0.16	0.31
—	3/8	1.00	1.16	1.31	0.16	0.34
—	1/2	1.22	1.34	1.53	0.22	0.44
3/4-16	—	1.00	1.16	1.31	0.16	0.34
—	1/2	1.22	1.34	1.53	0.22	0.44
1 1/16-12	—	1.41	1.53	1.75	0.22	0.50
1 5/16-12	—	1.69	1.78	2.03	0.22	0.56

Male Connectors

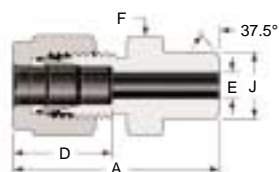

① The E dimension is the minimum nominal opening. These fittings may have a larger opening at the pipe/straight thread end.

Male Pipe Weld Connector

Tube OD	Male Pipe Weld Size	Basic Ordering Number	Dimensions				
			A	D	E ^①	F Flat	J
<i>Dimensions, in.</i>							
1/8	1/8	-200-1-2W	1.20	0.50	0.09	7/16	0.405
3/16	1/8	-300-1-2W	1.23	0.54	0.12	7/16	0.405
1/4	1/8	-400-1-2W	1.29	0.60	0.19	1/2 9/16	0.405 0.540
	1/4	-400-1-4W	1.49				
5/16	1/8	-500-1-2W	1.34	0.64	0.21 0.25	9/16	0.405 0.540
	1/4	-500-1-4W	1.52				
3/8	1/4	-600-1-4W	1.57	0.66	0.28	5/8 11/16 7/8 1 1/8	0.540 0.675 0.840 1.050
	3/8	-600-1-6W	1.57				
	1/2	-600-1-8W	1.82				
	3/4	-600-1-12W	1.88				
1/2	3/8	-810-1-6W	1.71	0.90	0.41	13/16 7/8 1 1/16	0.675 0.840 1.050
	1/2	-810-1-8W	1.93				
	3/4	-810-1-12W	1.99				
5/8	1/2	-1010-1-8W	1.93	0.96	0.50	15/16	0.840
3/4	3/4	-1210-1-12W	1.99	0.96	0.62	1 1/16	1.050
1	1	-1610-1-16W	2.45	1.23	0.88	1 3/8	1.315
1 1/4	1 1/4	-2000-1-20W	3.04	1.62	1.09	1 3/4	1.660
1 1/2	1 1/2	-2400-1-24W	3.50	1.97	1.34	2 1/8	1.900
2	2	-3200-1-32W	4.47	2.66	1.81	2 3/4	2.375

Tube OD	Male Pipe Weld Size, in.	Basic Ordering Number	Dimensions					
			A	D	E ^①	F Flat	F Flat ^②	J
<i>Dimensions, mm</i>								
3	1/8	-3M0-1-2W	30.5	12.9	2.4	12	1/2 in.	10.3
4	1/8	-4M0-1-2W	31.2	13.7	2.4	12	1/2 in.	10.3
6	1/8	-6M0-1-2W	32.8	15.3	4.8	14	1/2 in. 9/16 in.	10.3 13.7
	1/4	-6M0-1-4W	37.9					
8	1/8	-8M0-1-2W	34.2	16.2	5.4 6.4 6.4	15 15 22	9/16 in. 9/16 in. 7/8 in.	10.3 13.7 21.3
	1/4	-8M0-1-4W	38.7					
	1/2	-8M0-1-8W	45.6					
10	1/4	-10M0-1-4W	40.9	17.2	7.5 7.9 7.9	18 18 22	11/16 in. 11/16 in. 7/8 in.	13.7 17.1 21.3
	3/8	-10M0-1-6W	40.9					
	1/2	-10M0-1-8W	46.5					
12	1/4	-12M0-1-4W	43.4	22.8	7.5 9.5 9.5	22	13/16 in. 13/16 in. 7/8 in.	13.7 17.1 21.3
	3/8	-12M0-1-6W	43.4					
	1/2	-12M0-1-8W	49.0					
14	3/8	-14M0-1-6W	44.1	24.4	10.3	24	15/16 in.	17.1
15	1/2	-15M0-1-8W	49.0	24.4	11.9	24	15/16 in.	21.3
16	1/2	-16M0-1-8W	49.0	24.4	12.7	24	15/16 in.	21.3
18	1/2	-18M0-1-8W	50.5	24.4	13.9	27	1 1/16 in.	21.3
30	1 1/4	-30M0-1-20W	77.2	39.6	26.2	46	46	42.2
32	1 1/4	-32M0-1-20W	79.6	42.0	28.6	46	46	42.2
38	1 1/2	-38M0-1-24W	91.6	49.4	33.7	55	55	48.3

① The E dimension is the minimum nominal opening. These fittings may have a larger opening at the pipe/straight thread end.

② This dimension is for steel and aluminum fittings.

Female Connectors

Female NPT Thread

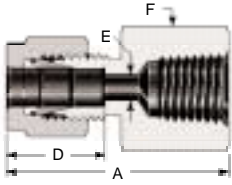

Tube OD	NPT Female Pipe Size in.	Basic Ordering Number	Dimensions			
			A	D	E	F Flat
<i>Dimensions, in.</i>						
1/16	1/16 1/8	-100-7-1 -100-7-2	0.93 0.96	0.34	0.05	7/16 9/16
1/8	1/8 1/4	-200-7-2 -200-7-4	1.13 1.32	0.50	0.09	9/16 3/4
3/16	1/8	-300-7-2	1.17	0.54	0.12	9/16
1/4	1/8	-400-7-2	1.23	0.60	0.19	9/16
	1/4	-400-7-4	1.41			3/4
	3/8	-400-7-6	1.48			7/8
	1/2	-400-7-8	1.67			1 1/16
5/16	1/8	-500-7-2	1.26	0.64	0.25	9/16
	1/4	-500-7-4	1.45			3/4
3/8	1/8	-600-7-2	1.29	0.66	0.28	5/8
	1/4	-600-7-4	1.48			3/4
	3/8	-600-7-6	1.54			7/8
	1/2	-600-7-8	1.73			1 1/16
	3/4	-600-7-12	1.88			1 5/16
1/2	1/4	-810-7-4	1.59	0.90	0.41	13/16
	3/8	-810-7-6	1.65			7/8
	1/2	-810-7-8	1.84			1 1/16
	3/4	-810-7-12	1.90			1 5/16
5/8	3/8	-1010-7-6	1.65	0.96	0.50	15/16
	1/2	-1010-7-8	1.84			1 1/16
	3/4	-1010-7-12	1.90			1 5/16
3/4	1/2	-1210-7-8	1.84	0.96	0.62	1 1/16
	3/4	-1210-7-12	1.90			1 5/16
7/8	3/4	-1410-7-12	1.96	1.02	0.72	1 5/16
1	3/4	-1610-7-12	2.10	1.23	0.88	1 3/8
	1	-1610-7-16	2.45			1 5/8
1 1/4	1 1/4	-2000-7-20	2.94	1.62	1.09	2 1/8
1 1/2	1 1/2	-2400-7-24	3.28	1.97	1.34	2 3/8
2	2	-3200-7-32	4.00	2.66	1.81	2 7/8
<i>Dimensions, mm</i>						
3	1/8	-3M0-7-2	28.7	12.9	2.4	14
	1/4	-3M0-7-4	33.5			19
4	1/8	-4M0-7-2	29.7	13.7	2.4	14
6	1/8	-6M0-7-2	31.3	15.3	4.8	14
	1/4	-6M0-7-4	35.8			19
	3/8	-6M0-7-6	37.6			22
	1/2	-6M0-7-8	42.5			27
8	1/8	-8M0-7-2	32.1	16.2	6.4	15
	1/4	-8M0-7-4	37.0			19
	3/8	-8M0-7-6	38.5			22
	1/2	-8M0-7-8	43.3			27
10	1/4	-10M0-7-4	37.8	17.2	7.9	19
	3/8	-10M0-7-6	39.4			22
	1/2	-10M0-7-8	44.2			27
12	1/4	-12M0-7-4	40.3	22.8	9.5	22
	3/8	-12M0-7-6	41.9			22
	1/2	-12M0-7-8	46.7			27
15	1/2	-15M0-7-8	46.7	24.4	11.9	27
16	1/2	-16M0-7-8	46.9	24.4	12.7	27
20	1/2	-20M0-7-8	47.9	26.0	15.9	30
	3/4	-20M0-7-12	49.7			35
22	3/4	-22M0-7-12	49.7	26.0	18.3	35
	1	-22M0-7-16	57.9			41
25	3/4	-25M0-7-12	53.4	31.3	21.8	35
	1	-25M0-7-16	62.3			41

Female Connectors

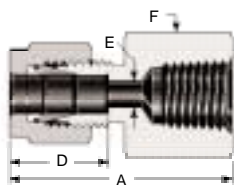

See page 7 for thread specifications.

Female ISO Tapered Thread (RT)

Tube OD	ISO Female Pipe Size in.	Basic Ordering Number	Dimensions			
			A	D	E	F Flat
Dimensions, in.						
1/4	1/8	-400-7-2RT	1.23	0.60	0.19	9/16
	1/4	-400-7-4RT	1.41			3/4
	3/8	-400-7-6RT	1.48			7/8
	1/2	-400-7-8RT	1.67			1 1/16
3/8	1/4	-600-7-4RT	1.48	0.66	0.28	3/4
	3/8	-600-7-6RT	1.54			7/8
	1/2	-600-7-8RT	1.73			1 1/16
1/2	1/4	-810-7-4RT	1.59	0.90	0.41	13/16
	3/8	-810-7-6RT	1.65			7/8
	1/2	-810-7-8RT	1.84			1 1/16
Dimensions, mm						
3	1/8	-3M0-7-2RT	28.7	12.9	2.4	14
6	1/8	-6M0-7-2RT	31.3	15.3	4.8	14
	1/4	-6M0-7-4RT	35.8			19
	3/8	-6M0-7-6RT	37.6			22
	1/2	-6M0-7-8RT	42.5			27
8	1/8	-8M0-7-2RT	32.1	16.2	6.4	15
	1/4	-8M0-7-4RT	37.0			19
	3/8	-8M0-7-6RT	38.5			22
	1/2	-8M0-7-8RT	43.3			27
10	1/8	-10M0-7-2RT	33.0	17.2	7.9	18
	1/4	-10M0-7-4RT	37.8			19
	3/8	-10M0-7-6RT	39.4			22
	1/2	-10M0-7-8RT	44.2			27
12	1/8	-12M0-7-2RT	35.5	22.8	8.3	22
	1/4	-12M0-7-4RT	40.3		9.5	22
	3/8	-12M0-7-6RT	41.9		9.5	22
	1/2	-12M0-7-8RT	46.7		9.5	27
	3/4	-12M0-7-12RT	49.0		9.5	35
15	3/8	-15M0-7-6RT	41.9	24.4	11.9	24
	1/2	-15M0-7-8RT	46.7			27
20	1/2	-20M0-7-8RT	47.9	26.0	15.9	30
	3/4	-20M0-7-12RT	49.7			35
22	3/4	-22M0-7-12RT	49.7	26.0	18.3	35
	1	-22M0-7-16RT	57.9			41
25	3/4	-25M0-7-12RT	53.4	31.3	21.8	35
	1	-25M0-7-16RT	62.3			41

Female Connectors

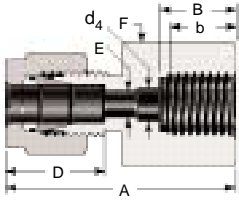

See page 7 for thread specifications.
ISO parallel gaskets are available.
See page 48.

Female ISO Parallel (Gauge) Thread (RG)

Tube OD	ISO Female Pipe Size in.	Basic Ordering Number	Dimensions						
			A	B	b	D	d ₄	E	F Flat
Dimensions, in.									
1/4	1/4	-400-7-4RG	1.48	0.51	0.39	0.60	0.22	0.19	3/4
	3/8	-400-7-6RG	1.48	0.56	0.37		0.26		15/16
	1/2	-400-7-8RG	1.71	0.74	0.57		0.26		1 1/16
5/16	1/4	-500-7-4RG	1.51	0.51	0.39	0.64	—	0.22	3/4
	1/2	-500-7-8RG	1.61	0.74	0.57		0.28	0.28	1 1/16
3/8	1/4	-600-7-4RG	1.54	0.51	0.39	0.66	—	0.22	3/4
	3/8	-600-7-6RG	1.52	0.56	0.39		0.26	0.26	15/16
	1/2	-600-7-8RG	1.65	0.74	0.57		0.28	0.28	1 1/16
1/2	3/8	-810-7-6RG	1.75	0.56	0.39	0.90	—	0.26	15/16
	1/2	-810-7-8RG	1.90	0.74	0.57		0.28	0.28	1 1/16
Dimensions, mm									
3	1/4	-3M0-7-4RG	35.3	12.9	10.0	12.9	5.5	2.4	19
6	1/4	-6M0-7-4RG	37.6	12.9	10.0	15.3	5.5	4.8	19
	3/8	-6M0-7-6RG	37.6	14.1	10.0		6.5		24
	1/2	-6M0-7-8RG	43.5	18.9	14.5		7.0		27
8	1/4	-8M0-7-4RG	38.5	12.9	10.0	16.2	5.5	5.5	19
	3/8	-8M0-7-6RG	36.2	14.1	10.0		6.5	6.5	24
	1/2	-8M0-7-8RG	41.0	18.9	14.5		7.0	7.0	27
10	1/4	-10M0-7-4RG	39.4	12.9	10.0	17.2	5.5	5.5	19
	3/8	-10M0-7-6RG	38.8	14.1	10.0		6.5	6.5	24
	1/2	-10M0-7-8RG	42.1	18.9	14.5		7.0	7.0	27
12	1/4	-12M0-7-4RG	41.9	12.9	10.0	22.8	5.5	5.5	22
	3/8	-12M0-7-6RG	44.4	14.1	10.0		6.5	6.5	24
	1/2	-12M0-7-8RG	48.2	18.9	14.5		7.0	7.0	27
20	1/2	-20M0-7-8RG	54.3	18.9	14.5	26.0	7.0	7.0	30
22	1/2	-22M0-7-8RG	54.3	18.9	14.5	26.0	7.0	7.0	30

Bulkhead Female NPT Connector

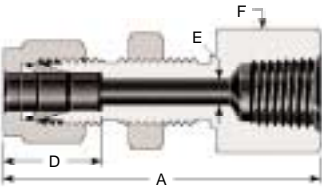

Tube OD	NPT Female Pipe Size in.	Basic Ordering Number	Dimensions					
			A	D	E	F Flat	Panel Hole Size	Max Panel Thickness
Dimensions, in.								
1/8	1/8	-200-71-2	1.76	0.50	0.09	9/16	21/64	0.50
1/4	1/8	-400-71-2	1.85	0.60	0.19	5/8	29/64	0.40
	1/4	-400-71-4	2.04			3/4		
3/8	1/4	-600-71-4	2.17	0.66	0.28	3/4	37/64	0.44
1/2	3/8	-810-71-6	2.43	0.90	0.41	15/16	49/64	0.50
	1/2	-810-71-8	2.62			1 1/16		
Dimensions, mm								
6	1/4	-6M0-71-4	51.8	15.3	4.8	19	11.5	10.2
12	1/2	-12M0-71-8	66.5	22.8	9.5	27	19.5	12.7

Reducers

Reducer

1 in. / 25 mm and under

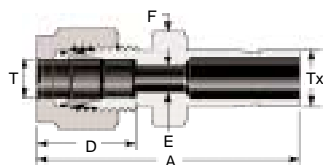

Over 1 in.

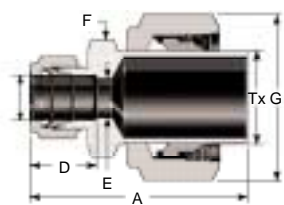

① Furnished with nut and preswaged ferrules.

T Tube OD	Tx Tube OD	Basic Ordering Number	Dimensions				
			A	D	E	F Flat	G Flat
<i>Dimensions, in.</i>							
1/16	1/8 1/4	-100-R-2 -100-R-4	1.15 1.24	0.34	0.05	5/16	—
1/8	1/16	-200-R-1	1.14	0.50	0.03	7/16	—
	1/8	-200-R-2	1.32		0.08	7/16	
	3/16	-200-R-3	1.35		0.09	7/16	
	1/4	-200-R-4	1.42		0.09	7/16	
	3/8	-200-R-6	1.48		0.09	7/16	
3/16	1/8	-300-R-2	1.37	0.54	0.08	7/16	—
	1/4	-300-R-4	1.46		0.12		
1/4	1/8	-400-R-2	1.45	0.60	0.08	1/2	—
	3/16	-400-R-3	1.48		0.12	1/2	
	1/4	-400-R-4	1.54		0.17	1/2	
	5/16	-400-R-5	1.57		0.19	1/2	
	3/8	-400-R-6	1.60		0.19	1/2	
	1/2	-400-R-8	1.82		0.19	9/16	
	5/8	-400-R-10	1.89		0.19	11/16	
5/16	3/8	-500-R-6	1.65	0.64	0.25	9/16	—
	1/2	-500-R-8	1.87				
3/8	1/4	-600-R-4	1.63	0.66	0.17	5/8	—
	3/8	-600-R-6	1.70		0.27	5/8	
	1/2	-600-R-8	1.91		0.28	5/8	
	5/8	-600-R-10	1.98		0.28	11/16	
	3/4	-600-R-12	1.98		0.28	13/16	
1/2	1/4	-810-R-4	1.77	0.90	0.17	13/16	—
	3/8	-810-R-6	1.84		0.27	13/16	
	1/2	-810-R-8	2.06		0.37	13/16	
	5/8	-810-R-10	2.12		0.41	13/16	
	3/4	-810-R-12	2.12		0.41	13/16	
	1	-810-R-16	2.37		0.41	1 1/16	
5/8	3/4	-1010-R-12	2.15	0.96	0.50	15/16	—
	7/8	-1010-R-14	2.21			15/16	
	1	-1010-R-16	2.40			1 1/16	
3/4	1/2	-1210-R-8	2.15	0.96	0.37	1 1/16	—
	1	-1210-R-16	2.46				
1	1 1/4	-1610-R-20 ^①	3.17	1.23	0.88	1 3/8	1 7/8
	1 1/2	-1610-R-24 ^①	3.51			1 5/8	2 1/4
	2	-1610-R-32 ^①	4.43			2 1/8	3
1 1/4	1 1/2	-2000-R-24 ^①	4.10	1.62	1.09	1 3/4	2 1/4
	2	-2000-R-32 ^①	4.93			2 1/8	3
1 1/2	2	-2400-R-32 ^①	5.17	1.97	1.34	2 1/8	3

T Tube OD	Tx Tube OD, in.	Basic Ordering Number	Dimensions			
			A	D	E	F Flat
<i>Dimensions, mm</i>						
2	1/8	-2M0-R-2	33.5	12.9	1.7	12
3	1/8	-3M0-R-2	33.5	12.9	2.0	12
	1/4	-3M0-R-4	36.1		2.4	
4	1/4	-4M0-R-4	37.1	13.7	2.4	12
6	1/8	-6M0-R-2	36.9	15.3	2.0	14
	1/4	-6M0-R-4	39.2		4.4	
	5/16	-6M0-R-5	39.9		4.8	
	3/8	-6M0-R-6	40.7		4.8	
	1/2	-6M0-R-8	46.3		4.8	
8	3/8	-8M0-R-6	42.0	16.2	6.4	15
	1/2	-8M0-R-8	47.6			
10	3/8	-10M0-R-6	44.2	17.2	6.8	18
	1/2	-10M0-R-8	49.8		7.9	
12	1/2	-12M0-R-8	52.3	22.8	9.3	22
	3/4	-12M0-R-12	53.8		9.5	
18	3/4	-18M0-R-12	56.1	24.4	14.7	27
	1	-18M0-R-16	62.4		15.1	
25	1	-25M0-R-16	69.5	31.3	20.2	35

Reducers

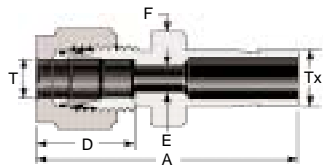

Reducer

T Tube OD	Tx Tube OD	Basic Ordering Number	Dimensions			
			A	D	E	F Flat
<i>Dimensions, mm</i>						
2	3	-2M0-R-3M	33.5	12.9	1.7	12
3	4	-3M0-R-4M	35.0	12.9	2.4	12
	6	-3M0-R-6M	36.1			12
	10	-3M0-R-10M	38.4			14
4	6	-4M0-R-6M	37.1	13.7	2.4	12
6	3	-6M0-R-3M	36.9	15.3	1.9	14
	8	-6M0-R-8M	39.9		4.8	14
	10	-6M0-R-10M	40.7		4.8	14
	12	-6M0-R-12M	46.3		4.8	14
	18	-6M0-R-18M	49.6		4.8	22
8	6	-8M0-R-6M	40.3	16.2	4.1	15
	10	-8M0-R-10M	42.0		6.4	
	12	-8M0-R-12M	47.6		6.4	
10	6	-10M0-R-6M	42.4	17.2	4.1	18
	8	-10M0-R-8M	43.4		5.6	18
	12	-10M0-R-12M	49.8		7.9	18
	15	-10M0-R-15M	51.3		7.9	18
	18	-10M0-R-18M	51.3		7.9	22
12	6	-12M0-R-6M	44.9	22.8	4.1	22
	8	-12M0-R-8M	45.9		5.6	22
	10	-12M0-R-10M	46.7		7.1	22
	16	-12M0-R-16M	53.8		9.5	22
	18	-12M0-R-18M	53.8		9.5	22
	20	-12M0-R-20M	56.1		9.5	22
	22	-12M0-R-22M	56.1		9.5	24
25	-12M0-R-25M	62.4	9.5	27		
16	12	-16M0-R-12M	53.0	24.4	8.8	24
18	12	-18M0-R-12M	54.6	24.4	8.8	27
	16	-18M0-R-16M	56.1		12.0	
	20	-18M0-R-20M	57.6		15.1	
	22	-18M0-R-22M	57.6		15.1	
	25	-18M0-R-25M	62.4		15.1	
20	16	-20M0-R-16M	57.9	26.0	12.0	30
	18	-20M0-R-18M	57.9		13.9	
	22	-20M0-R-22M	59.4		15.9	
	25	-20M0-R-25M	64.2		15.9	
22	18	-22M0-R-18M	57.9	26.0	13.9	30
	20	-22M0-R-20M	59.4		15.5	
	25	-22M0-R-25M	64.2		18.3	
25	18	-25M0-R-18M	63.1	31.3	13.9	35
	20	-25M0-R-20M	64.6		15.5	

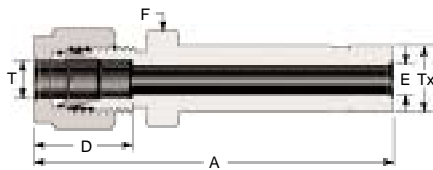

Use only long reducers in female Swagelok ports.

Long Reducer

T Tube OD	Tx Tube OD	Basic Ordering Number	Dimensions			
			A	D	E	F Flat
<i>Dimensions, in.</i>						
3/8	1/2	-600-RF-8	2.57	0.66	0.25	5/8

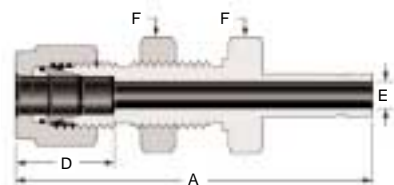

Bulkhead Reducer

Tube OD	Basic Ordering Number	Dimensions					
		A	D	E	F Flat	Panel Hole Size	Max Panel Thickness
<i>Dimensions, in.</i>							
1/8	-200-R1-2	1.95	0.50	0.08	1/2	21/64	0.50
1/4	-400-R1-4	2.20	0.60	0.17	5/8	29/64	0.40
3/8	-600-R1-6	2.41	0.66	0.27	3/4	37/64	0.44
1/2	-810-R1-8	2.87	0.90	0.37	15/16	49/64	0.50
5/8	-1010-R1-10	2.96	0.96	0.47	1 1/16	57/64	0.50
3/4	-1210-R1-12	3.21	0.96	0.58	1 3/16	1 1/64	0.66
1	-1610-R1-16	3.95	1.23	0.80	1 5/8	1 21/64	0.75

Port Connectors

x1 in. / 25 mm and under



Over 1 in. / 25mm

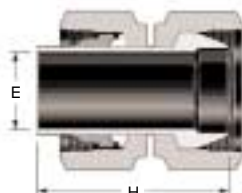

Port Connector

Tube OD	Basic Ordering Number	Dimensions	
		E	H
<i>Dimensions, in.</i>			
1/16	-101-PC	0.03	0.54
1/8	-201-PC	0.08	0.88
1/4	-401-PC	0.17	0.98
5/16	-501-PC	0.22	1.02
3/8	-601-PC	0.27	1.05
1/2	-811-PC	0.37	1.43
5/8	-1011-PC	0.47	1.49
3/4	-1211-PC	0.58	1.49
1	-1611-PC	0.80	1.94
1 1/4	-2000-PC ^①	1.02	2.72
1 1/2	-2400-PC ^①	1.25	3.31
2	-3200-PC ^①	1.72	4.56

Tube OD	Basic Ordering Number	Dimensions	
		E	H
<i>Dimensions, mm</i>			
3	-3M1-PC	1.9	22.2
6	-6M1-PC	4.1	25.0
8	-8M1-PC	5.6	26.0
10	-10M1-PC	7.1	27.1
12	-12M1-PC	8.8	36.2
15	-15M1-PC	11.2	37.8
16	-16M1-PC	12.0	37.8
18	-18M1-PC	13.9	37.8
20	-20M1-PC	15.5	39.4
25	-25M1-PC	19.9	49.3
28	-28M0-PC ^①	22.5	63.5
30	-30M0-PC ^①	24.3	67.6
32	-32M0-PC ^①	26.5	69.7
38	-38M0-PC ^①	31.6	81.9

① Furnished with nuts and preswaged ferrules.

Reducing Port Connector



T Tube OD	Tx Tube OD	Basic Ordering Number	Dimensions	
			E	H
<i>Dimensions, in.</i>				
1/8	1/16	-201-PC-1	0.03	0.72
1/4	1/16	-401-PC-1	0.03	0.75
	1/8	-401-PC-2	0.08	0.90
3/8	1/8	-601-PC-2	0.08	0.92
	1/4	-601-PC-4	0.17	1.00
1/2	1/4	-811-PC-4	0.17	1.17
	3/8	-811-PC-6	0.27	1.21
3/4	1/2	-1211-PC-8	0.37	1.49
1	1/2	-1611-PC-8	0.37	1.69
	3/4	-1611-PC-12	0.58	1.72

T Tube OD	Tx Tube OD	Basic Ordering Number	Dimensions	
			E	H
<i>Dimensions, mm</i>				
6	3	-6M1-PC-3M	1.9	22.9
8	6	-8M1-PC-6M	4.1	25.4
10	6	-10M1-PC-6M	4.1	25.8
	8	-10M1-PC-8M	5.6	26.3
12	6	-12M1-PC-6M	4.1	29.6
	8	-12M1-PC-8M	5.6	30.1
	10	-12M1-PC-10M	7.1	30.6
16	12	-16M1-PC-12M	8.8	37.5
28	25	-28M1-PC-25M	19.8	56.5
32	25	-32M1-PC-25M	19.8	60.3
38	25	-38M1-PC-25M	19.8	65.8

Caps and Plugs

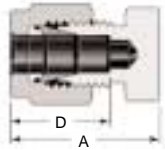

Cap

Tube OD	Basic Ordering Number	A	D
<i>Dimensions, in.</i>			
1/16	-100-C	0.59	0.34
1/8	-200-C	0.79	0.50
3/16	-300-C	0.84	0.54
1/4	-400-C	0.92	0.60
5/16	-500-C	0.96	0.64
3/8	-600-C	1.01	0.66
1/2	-810-C	1.15	0.90
5/8	-1010-C	1.18	0.96
3/4	-1210-C	1.24	0.96
7/8	-1410-C	1.34	1.02
1	-1610-C	1.51	1.23
1 1/4	-2000-C	2.10	1.62
1 1/2	-2400-C	2.54	1.97
2	-3200-C	3.41	2.66

Tube OD	Basic Ordering Number	A	D
<i>Dimensions, mm</i>			
2	-2M0-C	20.1	12.9
3	-3M0-C	20.1	12.9
4	-4M0-C	21.3	13.7
6	-6M0-C	23.1	15.3
8	-8M0-C	24.5	16.2
10	-10M0-C	26.6	17.2
12	-12M0-C	29.1	22.8
14	-14M0-C	29.9	24.4
15	-15M0-C	29.9	24.4
16	-16M0-C	29.9	24.4
18	-18M0-C	31.4	24.4
20	-20M0-C	34.0	26.0
22	-22M0-C	34.0	26.0
25	-25M0-C	38.5	31.3
28	-28M0-C	48.5	36.6
30	-30M0-C	53.4	39.6
32	-32M0-C	55.8	42.0
38	-38M0-C	65.4	49.4



Plug

Tube OD	Basic Ordering Number
<i>Dimensions, in.</i>	
1/16	-100-P
1/8	-200-P
3/16	-300-P
1/4	-400-P
5/16	-500-P
3/8	-600-P
1/2	-810-P
5/8	-1010-P
3/4	-1210-P
7/8	-1410-P
1	-1610-P
1 1/4	-2000-P
1 1/2	-2400-P
2	-3200-P

Tube OD	Basic Ordering Number
<i>Dimensions, mm</i>	
2	-2M0-P
3	-3M0-P
4	-4M0-P
6	-6M0-P
8	-8M0-P
10	-10M0-P
12	-12M0-P
15	-15M0-P
16	-16M0-P
18	-18M0-P
20	-20M0-P
22	-22M0-P
25	-25M0-P
28	-28M0-P
30	-30M0-P
32	-32M0-P
38	-38M0-P

Vent Protectors

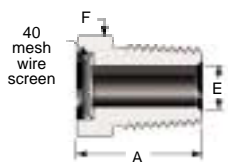

40 mesh 300 series stainless steel wire screen assembly

Vent Protector

Swagelok vent protectors, more commonly known as **mud dauber fittings**, protect open ends of instruments, tubing, outlet vents, and bleed-off lines.

The mesh wire screen prevents foreign objects, such as mud dauber insects, from entering and clogging various systems and causing damage.

Vent protectors are available in stainless steel and brass. To order brass, replace **SS** with **B** in the ordering number.

Example: **B**-MD-4

NPT Male Pipe Size	Ordering Number	A	E	F Flat
<i>Dimensions, in.</i>				
1/4	SS-MD-4	0.78	0.28	9/16
3/8	SS-MD-6	0.81	0.41	11/16
1/2	SS-MD-8	1.03	0.50	7/8
3/4	SS-MD-12	1.06	0.72	1 1/16

Flanges

- Swagelok tube fitting ends for use with 1/4 to 2 in. and 6 to 50 mm OD tubing
- Integrally machined forging; no weld seams or joints
- 316/DIN material number 1.4401 stainless steel (TÜV approved)
- ANSI flanges compatible with ASME B16.5
- DIN flanges compatible with DIN 2526 and DIN 2501
- JIS flanges compatible with JIS B 2238



ANSI Flanges

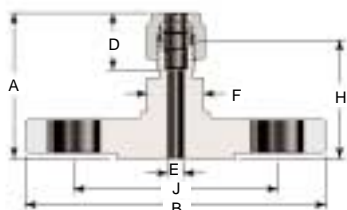

Tube OD	ANSI Flange NPS	Class	Ordering Number Raised Face Flange	Dimensions, in.						
				A	B	D	E	F Flat	H	J
1/4	1/2	150	SS-400-F8-150	1.61	3.50	0.60	0.19	13/16	1.32	2.38
3/8	1/2	300	SS-600-F8-300	1.79	3.75	0.66	0.28		1.50	2.62
1/2	1/2	150	SS-810-F8-150	1.78	3.50	0.90	0.41	1.50	2.38	
	1		SS-810-F16-150	1.90	4.25					
	2		SS-810-F32-150	2.09	6.00					
3/4	1	150	SS-1210-F16-150	1.98	4.25	0.96	0.62	1 1/4	1.58	3.12
1	1		SS-1610-F16-150	2.38		1.23	0.88	1 3/8	1.90	
1 1/2	2		SS-2400-F32-150	3.40	6.00	1.97	1.34	2 1/8	2.33	
2	2	SS-3200-F32-150	4.11	2.66		1.81	2 3/4	2.64	4.75	

DIN Flanges, Pressure Class PN 40

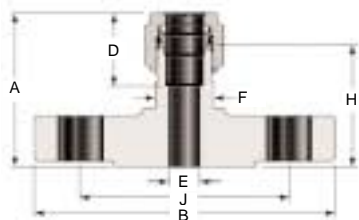

Tube OD	DIN Flange Size DN	Ordering Number Raised Face Flange	Dimensions, mm						
			A	B	D	E	F Flat	H	J
6	25	SS-6M0-F25M-40-C	47.5	115.0	15.3	4.8	20	40.1	85.0
12	15	SS-12M0-F15M-40-C	48.5	95.0	22.8	9.5		38.4	65.0
	25	SS-12M0-F25M-40-C	50.5	115.0				40.4	85.0
18	50	SS-12M0-F50M-40-C	55.3	165.0	24.4	15.1	32	45.2	125.0
	15	SS-18M0-F15M-40-C	51.8	95.0				41.7	65.0
25	25	SS-18M0-F25M-40-C	53.8	115.0				43.7	85.0
25	25	SS-25M0-F25M-40-C	64.0	115.0	31.3	21.8	35	51.8	125.0
38	50	SS-38M0-F50M-40-C	90.4		49.4	33.7	55	62.7	
50	50	SS-50M0-F50M-40-C	103.4	165.0	65.0	45.2	70	66.3	

JIS Flanges, Pressure Class 10K

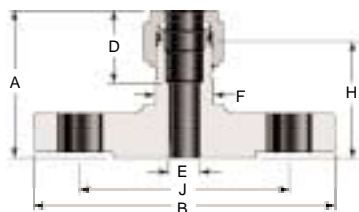

Tube OD	JIS Flange Size DN	Ordering Number Raised Face Flange	Dimensions						
			A	B	D	E	F Flat	H	J
<i>Dimensions, in.</i>									
1/4	15	SS-400-F15A-10K-RF	1.66	3.74	0.60	0.19	13/16	1.37	2.76
3/8		SS-600-F15A-10K-RF	1.72		0.66	0.28		1.43	
1/2		SS-810-F15A-10K-RF	1.83		0.90	0.41			
3/4		SS-1210-F15A-10K-RF	1.91		0.96	0.62	1 1/4	1.51	
1	25	SS-1610-F25A-10K-RF	2.40	4.92	1.23	0.88	1 3/8	1.92	3.54
2	50	SS-3200-F50A-10K-RF	4.01	6.10	2.66	1.81	2 3/4	2.54	4.72
<i>Dimensions, mm</i>									
12	15	SS-12M0-F15A-10K-RF	46.5	95.0	22.8	9.5	20	36.3	70.0
18	15	SS-18M0-F15A-10K-RF	48.5		24.4	15.1	32	38.4	
25	25	SS-25M0-F25A-10K-RF	61.0	125.0	31.3	21.8	35	48.8	90.0

Elbows

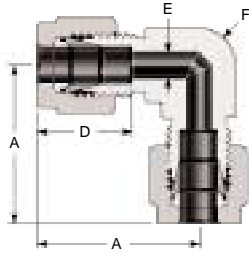

Tube ports are identical.

Union Elbow

Tube OD	Basic Ordering Number	Dimensions			
		A	D	E	F Flat
<i>Dimensions, in.</i>					
1/16	-100-9	0.70	0.34	0.05	3/8
1/8	-200-9	0.88	0.50	0.09	3/8
3/16	-300-9	1.00	0.54	0.12	1/2
1/4	-400-9	1.06	0.60	0.19	1/2
5/16	-500-9	1.13	0.64	0.25	9/16
3/8	-600-9	1.20	0.66	0.28	5/8
1/2	-810-9	1.42	0.90	0.41	13/16
5/8	-1010-9	1.50	0.96	0.50	15/16
3/4	-1210-9	1.57	0.96	0.62	1 1/16
7/8	-1410-9	1.76	1.02	0.72	1 3/8
1	-1610-9	1.93	1.23	0.88	1 3/8
1 1/4	-2000-9	2.67	1.62	1.09	1 11/16
1 1/2	-2400-9	3.10	1.97	1.34	2
2	-3200-9	4.22	2.66	1.81	2 3/4
<i>Dimensions, mm</i>					
3	-3M0-9	22.3	12.9	2.4	3/8 in.
4	-4M0-9	25.4	13.7	2.4	1/2 in.
6	-6M0-9	27.0	15.3	4.8	1/2 in.
8	-8M0-9	28.8	16.2	6.4	9/16 in.
10	-10M0-9	31.5	17.2	7.9	11/16 in.
12	-12M0-9	36.0	22.8	9.5	13/16 in.
14	-14M0-9	38.0	24.4	11.1	15/16 in.
15	-15M0-9	38.0	24.4	11.9	15/16 in.
16	-16M0-9	38.0	24.4	12.7	15/16 in.
18	-18M0-9	39.8	24.4	15.1	1 1/16 in.
20	-20M0-9	44.6	26.0	15.9	1 3/8 in.
22	-22M0-9	44.6	26.0	18.3	1 3/8 in.
25	-25M0-9	49.1	31.3	21.8	1 3/8 in.
28	-28M0-9	64.0	36.6	21.8	41
30	-30M0-9	69.9	39.6	26.2	46
32	-32M0-9	72.3	42.0	28.6	46
38	-38M0-9	84.0	49.4	33.7	55
50	-50M0-9	105.7	65.0	45.2	2 3/4 in.

Tube Socket Weld Elbow

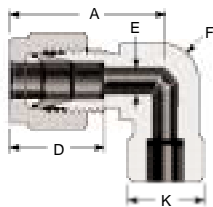

Tube OD	Socket Weld Size	Basic Ordering Number	Dimensions				
			A	D	E	F Flat	K
<i>Dimensions, in.</i>							
1/4	1/4	-400-9-4W	1.06	0.60	0.19	1/2	0.50
3/8	3/8	-600-9-6W	1.20	0.66	0.28	5/8	0.63
1/2	1/2	-810-9-8W	1.42	0.90	0.41	13/16	0.81
3/4	3/4	-1210-9-12W	1.57	0.96	0.62	1 1/16	1.06
1	1	-1610-9-16W	1.93	1.23	0.88	1 3/8	1.38

Elbows

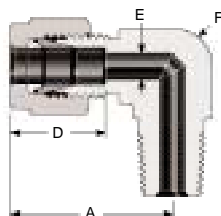

Male NPT Thread

Tube OD	NPT Male Pipe Size, in.	Basic Ordering Number	Dimensions			
			A	D	E ^①	F Flat
<i>Dimensions, in.</i>						
1/16	1/16 1/8	-100-2-1 -100-2-2	0.75	0.34	0.05	7/16
1/8	1/16	-200-2-1	0.93	0.50	0.09	7/16
	1/8	-200-2-2	0.93			7/16
	1/4	-200-2-4	0.97			1/2
3/16	1/8	-300-2-2	1.00	0.54	0.12	1/2
	1/4	-300-2-4				
1/4	1/16	-400-2-1	1.06	0.60	0.12	1/2
	1/8	-400-2-2	1.06			1/2
	1/4	-400-2-4	1.06			1/2
	3/8	-400-2-6	1.17			11/16
	1/2	-400-2-8	1.25			13/16
5/16	1/8	-500-2-2	1.13	0.64	0.19	9/16
	1/4	-500-2-4	1.13			9/16
	3/8	-500-2-6	1.20			11/16
3/8	1/8	-600-2-2	1.20	0.66	0.19	5/8
	1/4	-600-2-4	1.20			5/8
	3/8	-600-2-6	1.23			11/16
	1/2	-600-2-8	1.31			13/16
	3/4	-600-2-12	1.46			1 1/16
1/2	1/4	-810-2-4	1.42	0.90	0.28	13/16
	3/8	-810-2-6	1.42			13/16
	1/2	-810-2-8	1.42			13/16
	3/4	-810-2-12	1.57			1 1/16
5/8	3/8	-1010-2-6	1.50	0.96	0.38	15/16
	1/2	-1010-2-8	1.50			15/16
	3/4	-1010-2-12	1.57			1 1/16
3/4	1/2	-1210-2-8	1.57	0.96	0.47	1 1/16
	3/4	-1210-2-12				
7/8	3/4	-1410-2-12	1.76	1.02	0.62	1 3/8
1	3/4	-1610-2-12	1.93	1.23	0.62	1 3/8
	1	-1610-2-16				
1 1/4	1 1/4	-2000-2-20	2.67	1.62	1.09	1 11/16
1 1/2	1 1/2	-2400-2-24	3.10	1.97	1.34	2
2	2	-3200-2-32	4.22	2.66	1.81	2 3/4
<i>Dimensions, mm</i>						
3	1/8	-3M0-2-2	23.6	12.9	2.4	7/16 in.
	1/4	-3M0-2-4	24.6			1/2 in.
4	1/8	-4M0-2-2	25.4	13.7	2.4	1/2 in.
	1/4	-4M0-2-4				
6	1/8	-6M0-2-2	27.0	15.3	4.8	1/2 in.
	1/4	-6M0-2-4	27.0			1/2 in.
	3/8	-6M0-2-6	29.8			11/16 in.
	1/2	-6M0-2-8	31.8			13/16 in.
8	1/8	-8M0-2-2	28.8	16.2	4.8	9/16 in.
	1/4	-8M0-2-4	28.8			9/16 in.
	3/8	-8M0-2-6	30.6			11/16 in.
	1/2	-8M0-2-8	32.6			13/16 in.
10	1/8	-10M0-2-2	31.5	17.2	4.8	11/16 in.
	1/4	-10M0-2-4	31.5			11/16 in.
	3/8	-10M0-2-6	31.5			11/16 in.
	1/2	-10M0-2-8	33.5			13/16 in.
12	1/4	-12M0-2-4	36.0	22.8	7.1	13/16 in.
	3/8	-12M0-2-6	36.0			13/16 in.
	1/2	-12M0-2-8	36.0			13/16 in.
	3/4	-12M0-2-12	39.8			1 1/16 in.
15	1/2	-15M0-2-8	38.0	24.4	11.9	15/16 in.
16	3/8	-16M0-2-6	38.0	24.4	9.5	15/16 in.
	1/2	-16M0-2-8	38.0			15/16 in.
	3/4	-16M0-2-12	39.8			1 1/16 in.
18	1/2	-18M0-2-8	39.8	24.4	11.9	1 1/16 in.
	3/4	-18M0-2-12				
20	1/2	-20M0-2-8	44.6	26.0	11.9	1 3/8 in.
	3/4	-20M0-2-12				
22	3/4	-22M0-2-12	44.6	26.0	15.9	1 3/8 in.
	1	-22M0-2-16				
25	3/4	-25M0-2-12	49.1	31.3	15.9	1 3/8 in.
	1	-25M0-2-16				
30	1 1/4	-30M0-2-20	69.9	39.6	26.2	46
32	1 1/4	-32M0-2-20	72.3	42.0	27.8	46
38	1 1/2	-38M0-2-24	84.0	49.4	33.7	55

① The E dimension is the minimum nominal opening. These fittings may have a larger opening at the pipe/straight thread end.

Elbows

Male ISO Tapered Thread

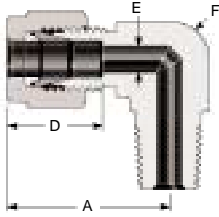

See page 7 for thread specifications.

Tube OD	ISO Male Pipe Size, in.	Basic Ordering Number	Dimensions			
			A	D	E ^①	F Flat, in.
<i>Dimensions, in.</i>						
1/4	1/8	-400-2-2RT	1.06	0.60	0.19	1/2
	1/4	-400-2-4RT	1.06			1/2
	3/8	-400-2-6RT	1.17			11/16
	1/2	-400-2-8RT	1.25			13/16
5/16	1/4	-500-2-4RT	1.13	0.64	0.25	9/16
3/8	1/4	-600-2-4RT	1.20	0.66	0.28	5/8
	3/8	-600-2-6RT	1.23			11/16
<i>Dimensions, mm</i>						
3	1/8	-3M0-2-2RT	23.6	12.9	2.4	7/16
	1/4	-3M0-2-4RT	24.6			1/2
4	1/8	-4M0-2-2RT	25.4	13.7	2.4	1/2
	1/4	-4M0-2-4RT				
6	1/8	-6M0-2-2RT	27.0	15.3	4.8	1/2
	1/4	-6M0-2-4RT	27.0			1/2
	3/8	-6M0-2-6RT	29.8			11/16
	1/2	-6M0-2-8RT	31.8			13/16
8	1/8	-8M0-2-2RT	28.8	16.2	4.8	9/16
	1/4	-8M0-2-4RT	28.8			9/16
	3/8	-8M0-2-6RT	30.6			11/16
	1/2	-8M0-2-8RT	32.6			13/16
10	1/4	-10M0-2-4RT	31.5	17.2	7.1	11/16
	3/8	-10M0-2-6RT	31.5			11/16
	1/2	-10M0-2-8RT	33.5			13/16
12	1/8	-12M0-2-2RT	36.0	22.8	4.8	13/16
	1/4	-12M0-2-4RT	36.0			13/16
	3/8	-12M0-2-6RT	36.0			13/16
	1/2	-12M0-2-8RT	36.0			13/16
	3/4	-12M0-2-12RT	39.8			1 1/16
16	3/8	-16M0-2-6RT	38.0	24.4	9.5	15/16
	1/2	-16M0-2-8RT				11.9
18	1/2	-18M0-2-8RT	39.8	24.4	11.9	1 1/16
	3/4	-18M0-2-12RT				15.1
20	1/2	-20M0-2-8RT	44.6	26.0	11.9	1 3/8
	3/4	-20M0-2-12RT				15.9
22	3/4	-22M0-2-12RT	44.6	26.0	15.9	1 3/8
	1	-22M0-2-16RT				18.3
25	3/4	-25M0-2-12RT	49.1	31.3	15.9	1 3/8
	1	-25M0-2-16RT				21.8

① The E dimension is the minimum nominal opening. These fittings may have a larger opening at the pipe/straight thread end.

Positionable Male Elbow—SAE/MS Straight Thread

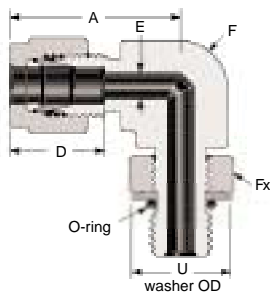

Adapts to SAE J1926/1 boss.

① The E dimension is the minimum nominal opening. These fittings may have a larger opening at the pipe/straight thread end.

Tube OD	SAE/MS Thread Size	Basic Ordering Number	Dimensions					
			A	D	E ^①	F Flat	Fx Flat	U
<i>Dimensions, in.</i>								
1/4	7/16-20	-400-2-4ST	1.12	0.60	0.19	1/2	9/16	0.65
	9/16-18	-400-2-6ST	1.20					
5/16	1/2-20	-500-2-5ST	1.19	0.64	0.23	9/16	5/8	0.72
3/8	9/16-18	-600-2-6ST	1.26	0.66	0.28	5/8	11/16	0.79
	3/4-16	-600-2-8ST	1.37					
1/2	3/4-16	-810-2-8ST	1.48	0.90	0.41	13/16	7/8	1.01
5/8	7/8-14	-1010-2-10ST	1.56	0.96	0.50	15/16	1	1.16
3/4	1 1/16-12	-1210-2-12ST	1.63	0.96	0.62	1 1/16	1 1/4	1.44
7/8	1 3/16-12	-1410-2-14ST	1.70	1.02	0.72	1 3/16	1 3/8	1.59
1	1 5/16-12	-1610-2-16ST	1.99	1.23	0.88	1 3/8	1 1/2	1.73
1 1/4	1 5/8-12	-2000-2-20ST	2.67	1.62	1.09	1 11/16	1 7/8	2.16
1 1/2	1 7/8-12	-2400-2-24ST	3.07	1.97	1.34	2	2 1/8	2.45
2	2 1/2-12	-3200-2-32ST	4.22	2.66	1.81	2 3/4	2 3/4	3.16

Elbows

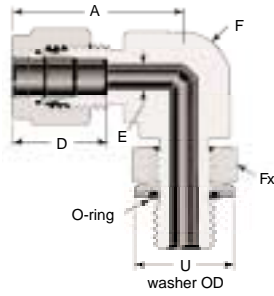

Positionable Male Elbow—ISO Parallel Thread

Tube OD	ISO Male Pipe Size, in.	Basic Ordering Number	Dimensions					
			A	D	E ^①	F Flat, in.	Fx Flat, in.	U
<i>Dimensions, in.</i>								
1/4	1/8	-400-2-2PR	1.06	0.60	0.16	1/2	9/16	0.68
	1/4	-400-2-4PR	1.14		0.19	5/8	3/4	0.90
3/8	1/4	-600-2-4PR	1.20	0.66	0.23	5/8	3/4	0.90
	3/8	-600-2-6PR	1.31		0.28	13/16	7/8	1.04
1/2	1/4	-810-2-4PR	1.42	0.90	0.23	13/16	3/4	0.90
	3/8	-810-2-6PR	1.42		0.31	13/16	7/8	1.04
	1/2	-810-2-8PR	1.50		0.41	15/16	1 1/16	1.26
5/8	1/2	-1010-2-8PR	1.50	0.96	0.47	15/16	1 1/16	1.26
3/4	1/2	-1210-2-8PR	1.57	0.96	0.47	1 1/16	1 1/16	1.26
	3/4	-1210-2-12PR			0.62		1 3/8	1.62
1	3/4	-1610-2-12PR	1.93	1.23	0.62	1 3/8	1 3/8	1.62
	1	-1610-2-16PR			0.78		1 5/8	1.91
<i>Dimensions, mm</i>								
6	1/8	-6M0-2-2PR	27.0	15.3	4.0	1/2	9/16	17.3
	1/4	-6M0-2-4PR	29.0		4.8	5/8	3/4	22.9
8	1/8	-8M0-2-2PR	28.8	16.2	4.0	9/16	9/16	17.3
	1/4	-8M0-2-4PR	29.9		5.9	5/8	3/4	22.9
10	1/4	-10M0-2-4PR	33.5	17.2	5.9	13/16	3/4	22.9
	3/8	-10M0-2-6PR			7.9	7/8	26.4	
12	1/4	-12M0-2-4PR	36.0	22.8	5.9	13/16	3/4	22.9
	3/8	-12M0-2-6PR	36.0		7.9	13/16	7/8	26.4
	1/2	-12M0-2-8PR	38.0		9.5	15/16	1 1/16	32.0
	3/4	-12M0-2-12PR	39.8		9.5	1 1/16	1 3/8	41.1

① The E dimension is the minimum nominal opening. These fittings may have a larger opening at the pipe/straight thread end.

Male Pipe Weld Elbow

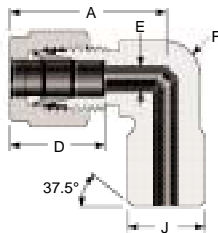

Tube OD	Male Pipe Weld Size	Basic Ordering Number	Dimensions				
			A	D	E ^①	F Flat	J
<i>Dimensions, in.</i>							
1/4	1/8	-400-2-2W	1.06	0.60	0.19	1/2	0.405
	1/4	-400-2-4W					0.540
3/8	1/4	-600-2-4W	1.20	0.66	0.28	5/8	0.540
1/2	1/2	-810-2-8W	1.42	0.90	0.41	13/16	0.840
3/4	3/4	-1210-2-12W	1.57	0.96	0.62	1 1/16	1.050

① The E dimension is the minimum nominal opening. These fittings may have a larger opening at the pipe/straight thread end.

Elbows

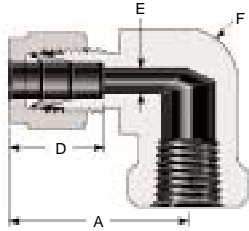

Female Elbow—NPT Thread

Tube OD	NPT Female Pipe Size, in.	Basic Ordering Number	Dimensions							
			A	D	E	F Flat, in.				
<i>Dimensions, in.</i>										
1/8	1/8 1/4	-200-8-2 -200-8-4	0.97 1.08	0.50	0.09	1/2 11/16				
3/16	1/8	-300-8-2	1.00	0.54	0.12	1/2				
1/4	1/8	-400-8-2	1.06	0.60	0.19	1/2 11/16 13/16 1				
	1/4	-400-8-4	1.17							
	3/8	-400-8-6	1.25							
	1/2	-400-8-8	1.36							
5/16	1/8 1/4	-500-8-2 -500-8-4	1.13 1.20	0.64	0.25	9/16 11/16				
	3/8	1/8	-600-8-2	1.20	0.66	0.28	5/8 11/16 13/16 1			
1/4		-600-8-4	1.23							
3/8		-600-8-6	1.31							
1/2		-600-8-8	1.42							
1/2	1/4 3/8 1/2	-810-8-4 -810-8-6 -810-8-8	1.42 1.42 1.53	0.90	0.41	13/16 13/16 1				
	5/8	3/8 1/2	-1010-8-6 -1010-8-8				1.50 1.57	0.96	15/16 1 1/16	
		3/4	1/2 3/4				-1210-8-8 -1210-8-12			1.57 1.76
7/8	3/4		-1410-8-12	1.76	1.02	0.72	1 3/8			
1	3/4 1	-1610-8-12 -1610-8-16	1.93 2.11	1.23	0.88	1 3/8 1 11/16				
	<i>Dimensions, mm</i>									
6	1/8 1/4 1/2	-6M0-8-2 -6M0-8-4 -6M0-8-8	27.0 29.8 34.6	15.3	4.8	1/2 11/16 1				
	8	1/4	-8M0-8-4				30.6	16.2	6.4	11/16
	10	1/8 1/4	-10M0-8-2 -10M0-8-4				31.5 33.5	17.2	7.9	11/16 13/16
12		1/4 1/2	-12M0-8-4 -12M0-8-8	36.0 38.8	22.8	9.5	13/16 1			
	16	1/2	-16M0-8-8	39.5				24.4	12.7	1 1/16

45° Male Elbow—NPT Thread

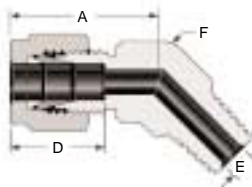

① The E dimension is the minimum nominal opening. These fittings may have a larger opening at the pipe/straight thread end.

Tube OD	NPT Male Pipe Size	Basic Ordering Number	Dimensions				
			A	D	E ^①	F Flat	
<i>Dimensions, in.</i>							
1/4	1/8 1/4	-400-5-2 -400-5-4	0.97	0.60	0.19	1/2	
3/8	1/8 1/4 3/8	-600-5-2 -600-5-4 -600-5-6	1.10 1.10 1.15	0.66	0.19 0.28 0.28	5/8 5/8 13/16	
	1/2	3/8 1/2	-810-5-6 -810-5-8		1.26	0.38 0.41	13/16
		3/4	3/4		-1210-5-12	1.33	0.96
1	1	-1610-5-16	1.59	1.23	0.88	1 3/8	

45° Positionable Male Elbow—SAE/MS Straight Thread

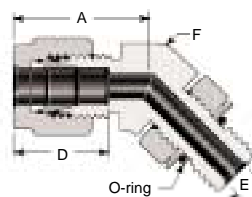

Adapts to SAE J1926/1 boss.

① The E dimension is the minimum nominal opening. These fittings may have a larger opening at the pipe/straight thread end.

Tube OD	SAE/MS Thread Size	Basic Ordering Number	Dimensions			
			A	D	E ^①	F Flat
<i>Dimensions, in.</i>						
1/4	7/16-20	-400-5-4ST	1.01	0.60	0.19	1/2
3/8	9/16-18	-600-5-6ST	1.10	0.66	0.28	5/8
1/2	3/4-16	-810-5-8ST	1.26	0.90	0.41	13/16
3/4	1 1/16-12	-1210-5-12ST	1.33	0.96	0.62	1 1/16
1	1 5/16-12	-1610-5-16ST	1.59	1.23	0.88	1 3/8

Tees

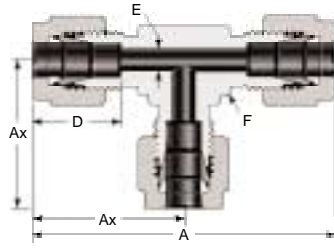

Union Tees

Tube OD	Basic Ordering Number	Dimensions				
		A	Ax	D	E	F Flat
<i>Dimensions, in.</i>						
1/16	-100-3	1.40	0.70	0.34	0.05	3/8
1/8	-200-3	1.76	0.88	0.50	0.09	3/8
3/16	-300-3	1.92	0.96	0.54	0.12	7/16
1/4	-400-3	2.12	1.06	0.60	0.19	1/2
5/16	-500-3	2.34	1.17	0.64	0.25	5/8
3/8	-600-3	2.40	1.20	0.66	0.28	5/8
1/2	-810-3	2.84	1.42	0.90	0.41	13/16
5/8	-1010-3	3.06	1.53	0.96	0.50	1
3/4	-1210-3	3.14	1.57	0.96	0.62	1 1/16
7/8	-1410-3	3.52	1.76	1.02	0.72	1 3/8
1	-1610-3	3.86	1.93	1.23	0.88	1 3/8
1 1/4	-2000-3	5.34	2.67	1.62	1.09	1 11/16
1 1/2	-2400-3	6.20	3.10	1.97	1.34	2
2	-3200-3	8.44	4.22	2.66	1.81	2 3/4
<i>Dimensions, mm</i>						
2	-2M0-3	44.7	22.3	12.9	1.7	3/8 in.
3	-3M0-3	44.7	22.3	12.9	2.4	3/8 in.
4	-4M0-3	50.8	25.4	13.7	2.4	1/2 in.
6	-6M0-3	53.9	27.0	15.3	4.8	1/2 in.
8	-8M0-3	59.7	29.9	16.2	6.4	5/8 in.
10	-10M0-3	63.0	31.5	17.2	7.9	11/16 in.
12	-12M0-3	72.0	36.0	22.8	9.5	13/16 in.
14	-14M0-3	77.6	38.8	24.4	11.1	1 in.
15	-15M0-3	77.6	38.8	24.4	11.9	1 in.
16	-16M0-3	77.6	38.8	24.4	12.7	1 in.
18	-18M0-3	79.6	39.8	24.4	15.1	1 1/16 in.
20	-20M0-3	89.3	44.6	26.0	15.9	1 3/8 in.
22	-22M0-3	89.3	44.6	26.0	18.3	1 3/8 in.
25	-25M0-3	98.3	49.1	31.3	21.8	1 3/8 in.
28	-28M0-3	128.0	64.0	36.6	21.8	41
30	-30M0-3	139.7	69.9	39.6	26.2	46
32	-32M0-3	144.6	72.3	42.0	28.6	46
38	-38M0-3	168.0	84.0	49.4	33.7	55
50	-50M0-3	211.3	105.7	65.0	45.2	2 3/4 in.

Reducing Union Tees

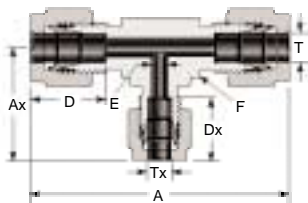

T Tube OD	Tx Tube OD	Basic Ordering Number	Dimensions							
			A	Ax	D	Dx	E	F Flat		
<i>Dimensions, in.</i>										
3/8	1/4	-600-3-6-4	2.40	1.14	0.66	0.60	0.19	5/8		
1/2	1/4 3/8	-810-3-8-4	2.84	1.25	0.90	0.60	0.19	13/16		
		-810-3-8-6		1.31					0.66	0.28
5/8	3/8	-1010-3-10-6	3.06	1.42	0.96	0.66	0.28	1		
3/4	3/8 1/2	-1210-3-12-6	3.14	1.46	0.96	0.66	0.28	1 1/16		
		-1210-3-12-8		1.57					0.90	0.41
1	3/8 1/2 3/4	-1610-3-16-6	3.86	1.65	1.23	0.66	0.28	1 3/8		
		-1610-3-16-8		1.76					0.90	0.41
		-1610-3-16-12		1.76					0.96	0.62
1 1/4	1	-2000-3-20-16	5.34	2.17	1.62	1.23	0.88	1 11/16		
1 1/2	1	-2400-3-24-16	6.20	2.36	1.97	1.23	0.88	2		
2	1	-3200-3-32-16	8.44	2.79	2.66	1.23	0.88	2 3/4		

Tees

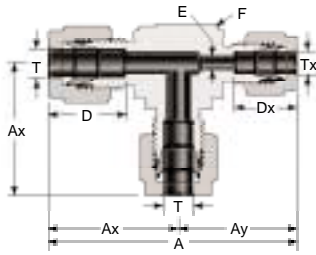

Reducing Union Tees

T Tube OD	Tx Tube OD	Basic Ordering Number	Dimensions						
			A	Ax	Ay	D	Dx	E	F Flat
<i>Dimensions, in.</i>									
3/8	1/4	-600-3-4-6	2.34	1.20	1.14	0.66	0.60	0.19	5/8

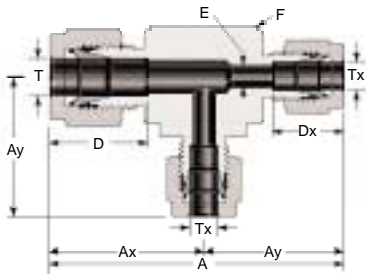

T Tube OD	Tx Tube OD	Basic Ordering Number	Dimensions						
			A	Ax	Ay	D	Dx	E	F Flat
<i>Dimensions, in.</i>									
1/2	3/8	-810-3-6-6	2.73	1.42	1.31	0.90	0.66	0.28	13/16
5/8	3/8	-1010-3-6-6	2.95	1.53	1.42	0.96	0.66	0.28	1
3/4	3/8	-1210-3-6-6	3.03	1.57	1.46	0.96	0.66	0.28	1 1/16

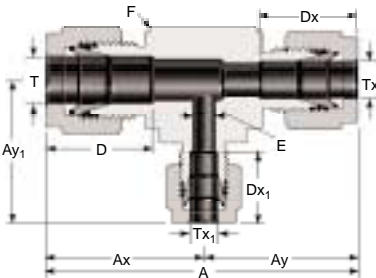

T Tube OD	Tx Tube OD	Tx ₁ Tube OD	Basic Ordering Number	Dimensions								
				A	Ax	Ay	Ay ₁	D	Dx	Dx ₁	E	F Flat
<i>Dimensions, in.</i>												
5/8	1/2	3/8	-1010-3-8-6	3.06	1.53	1.53	1.42	0.96	0.90	0.66	0.28	1
3/4	1/2	3/8	-1210-3-8-6	3.14	1.57	1.57	1.46	0.96	0.90	0.66	0.28	1 1/16
1	3/4	3/8	-1610-3-12-6	3.69	1.93	1.76	1.65	1.23	0.96	0.66	0.28	1 3/8

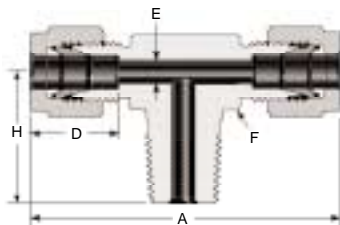

Male Branch Tee—NPT Thread

Tube OD	NPT Male Pipe Size, in.	Basic Ordering Number	Dimensions				
			A	D	E ^①	F Flat, in.	H
<i>Dimensions, in.</i>							
1/8	1/8	-200-3TTM	1.86	0.50	0.09	7/16	0.70
	1/4	-200-3-4TTM	1.94				
3/16	1/8	-300-3TTM	1.92	0.54	0.12	7/16	0.70
1/4	1/8	-400-3TTM	2.12	0.60	0.19	1/2	0.74
	1/4	-400-3-4TTM					
5/16	1/8	-500-3TTM	2.34	0.64	0.19	5/8	0.82
3/8	1/4	-600-3TTM	2.40	0.66	0.28	5/8	1.00
	3/8	-600-3-6TTM					
1/2	3/8	-810-3TTM	2.84	0.90	0.38	13/16	1.11
	1/2	-810-3-8TTM					
5/8	1/2	-1010-3TTM	3.06	0.96	0.47	1	1.41
3/4	3/4	-1210-3TTM	3.14	0.96	0.62	1 1/16	1.45
<i>Dimensions, mm</i>							
6	1/8	-6M0-3TTM	53.9	15.3	4.8	1/2	18.8
	1/4	-6M0-3-4TTM					
8	1/8	-8M0-3TTM	59.7	16.2	4.8	5/8	20.8
	1/4	-8M0-3-4TTM					
10	1/4	-10M0-3TTM	67.0	17.2	7.1	13/16	26.2
12	3/8	-12M0-3TTM	72.0	22.8	9.5	13/16	28.2
	1/4	-12M0-3-4TTM					
	1/2	-12M0-3-8TTM					
16	1/2	-16M0-3TTM	77.6	24.4	11.9	1	35.8

① The E dimension is the minimum nominal opening. These fittings may have a larger opening at the pipe/straight thread end.

Tees

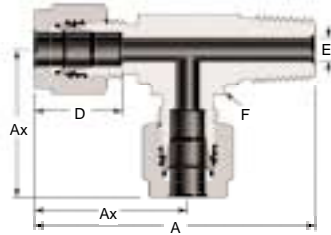

① The E dimension is the minimum nominal opening. These fittings may have a larger opening at the pipe/straight thread end.

Male Run Tee—NPT Thread

Tube OD	NPT Male Pipe Size, in.	Basic Ordering Number	Dimensions				
			A	Ax	D	E ^①	F Flat, in.
<i>Dimensions, in.</i>							
1/8	1/8 1/4	-200-3TMT -200-3-4TMT	1.63 1.89	0.93 0.97	0.50	0.09	7/16 1/2
3/16	1/8	-300-3TMT	1.66	0.96	0.54	0.12	7/16
1/4	1/8 1/4	-400-3TMT -400-3-4TMT	1.80 1.98	1.06	0.60	0.19	1/2
5/16	1/8	-500-3TMT	1.99	1.17	0.64	0.19	5/8
3/8	1/4 3/8	-600-3TMT -600-3-6TMT	2.20 2.42	1.20 1.31	0.66	0.28	5/8 13/16
1/2	3/8 1/2	-810-3TMT -810-3-8TMT	2.53 2.72	1.42	0.90	0.38 0.41	13/16
5/8	1/2	-1010-3TMT	2.88	1.50	0.96	0.47	15/16
3/4	3/4	-1210-3TMT	3.02	1.57	0.96	0.62	1 1/16
<i>Dimensions, mm</i>							
6	1/8 1/4	-6M0-3TMT -6M0-3-4TMT	45.8 50.3	27.0	15.3	4.8	1/2
8	1/4	-8M0-3-4TMT	55.3	29.9	16.2	6.4	5/8
12	1/4 1/2	-12M0-3-4TMT -12M0-3-8TMT	64.2 69.0	36.0	22.8	7.1 9.5	13/16
16	1/2	-16M0-3TMT	73.1	38.0	24.4	11.9	15/16

Positionable Male Run Tee—SAE/MS Straight Thread

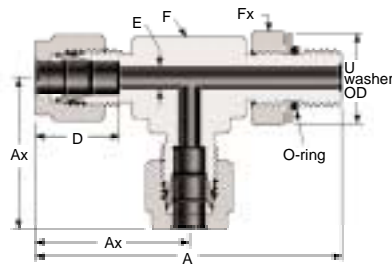

Adapts to SAE J1926/boss.

① The E dimension is the minimum nominal opening. These fittings may have a larger opening at the pipe/straight thread end.

Tube OD	SAE/MS Male Pipe Size	Basic Ordering Number	Dimensions						
			A	Ax	D	E ^①	F Flat	Fx Flat	U
<i>Dimensions, in.</i>									
1/4	7/16-20	-400-3TST	2.24	1.12	0.60	0.19	1/2	9/16	0.65
3/8	9/16-18	-600-3TST	2.53	1.26	0.66	0.28	5/8	11/16	0.79
1/2	3/4-16	-810-3TST	2.97	1.48	0.90	0.41	13/16	7/8	1.01
3/4	1 1/16-12	-1210-3TST	3.55	1.63	0.96	0.62	1 1/16	1 1/4	1.44
1	1 5/16-12	-1610-3TST	4.10	1.99	1.23	0.88	1 3/8	1 1/2	1.73
1 1/4	1 5/8-12	-2000-3TST	4.96	2.67	1.62	1.09	1 11/16	1 7/8	2.16
1 1/2	1 7/8-12	-2400-3TST	5.45	3.07	1.97	1.34	2	2 1/8	2.45
2	2 1/2-12	-3200-3TST	7.04	4.22	2.66	1.81	2 3/4	2 3/4	3.16

Positionable Male Run Tee—ISO Parallel Thread

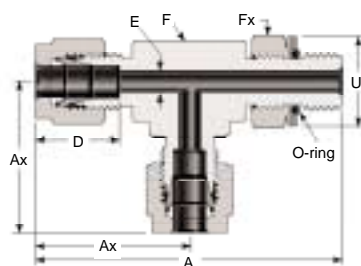

See page 7 for thread specifications.

① The E dimension is the minimum nominal opening. These fittings may have a larger opening at the pipe/straight thread end.

Tube OD	ISO Male Pipe Size, in.	Basic Ordering Number	Dimensions						
			A	Ax	D	E ^①	F Flat, in.	Fx Flat, in.	U
<i>Dimensions, in.</i>									
1/4	1/8 1/4	-400-3TRT -400-3-4TRT	2.10 2.41	1.06 1.14	0.60	0.16 0.19	1/2 5/8	9/16 3/4	0.68 0.90
3/8	1/4	-600-3TRT	2.47	1.20	0.66	0.23	5/8	3/4	0.90
1/2	3/8 1/2	-810-3TRT -810-3-8TRT	2.88 3.21	1.42 1.50	0.90	0.31 0.41	13/16 15/16	7/8 1 1/16	1.04 1.26
5/8	1/2	-1010-3TRT	3.21	1.50	0.96	0.47	15/16	1 1/16	1.26
3/4	3/4 1/2	-1210-3TRT -1210-3-8TRT	3.49 3.35	1.57	0.96	0.62 0.47	1 1/16	1 3/8 1 1/16	1.62 1.26
1	1	-1610-3TRT	4.04	1.93	1.23	0.78	1 3/8	1 5/8	1.91
<i>Dimensions, mm</i>									
6	1/8 1/4	-6M0-3TRT -6M0-3-4TRT	53.4 61.2	27.0 29.0	15.3	4.0 4.8	1/2 5/8	9/16 3/4	17.3 22.9
8	1/8 1/4	-8M0-3TRT -8M0-3-4TRT	56.3 62.1	28.8 29.9	16.2	4.0 6.4	9/16 5/8	9/16 3/4	17.3 22.9
10	1/4	-10M0-3TRT	68.6	33.5	17.2	5.9	13/16	3/4	22.9
12	3/8 1/2	-12M0-3TRT -12M0-3-8TRT	73.1 81.5	36.0 38.0	22.8	7.9 9.5	13/16 15/16	7/8 1 1/16	26.4 32.0

Tees

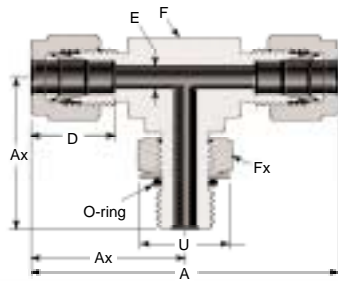

Adapts to SAE J1926 straight thread boss and SAE J1926/1 boss.

① The E dimension is the minimum nominal opening. These fittings may have a larger opening at the pipe/straight thread end.

Positionable Male Branch Tee—SAE/MS Straight Thread

Tube OD	SAE/MS Male Pipe Size	Basic Ordering Number	Dimensions						
			A	Ax	D	E ^①	F Flat	Fx Flat	U
<i>Dimensions, in.</i>									
1/4	7/16-20	-400-3TTS	2.24	1.12	0.60	0.19	1/2	9/16	0.65
3/8	9/16-18	-600-3TTS	2.52	1.26	0.66	0.28	5/8	11/16	0.79
1/2	3/4-16	-810-3TTS	2.96	1.48	0.90	0.41	13/16	7/8	1.01
3/4	1 1/16-12	-1210-3TTS	3.26	1.63	0.96	0.62	1 1/16	1 1/4	1.44
1	1 5/16-12	-1610-3TTS	3.98	1.99	1.23	0.88	1 3/8	1 1/2	1.73
1 1/4	1 5/8-12	-2000-3TTS	5.34	2.67	1.62	1.09	1 11/16	1 7/8	2.16
1 1/2	1 7/8-12	-2400-3TTS	6.14	3.07	1.97	1.34	2	2 1/8	2.45
2	2 1/2-12	-3200-3TTS	8.44	4.22	2.66	1.81	2 3/4	2 3/4	3.16

Positionable Male Branch Tee—ISO Parallel Thread

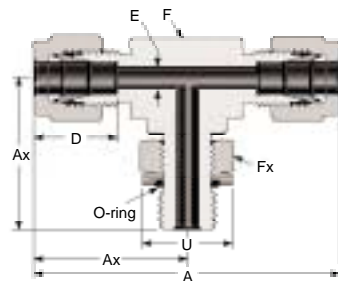

Tube ports are identical.

See page 7 for thread specifications.

① The E dimension is the minimum nominal opening. These fittings may have a larger opening at the pipe/straight thread end.

Tube OD	ISO Male Pipe Size, in.	Basic Ordering Number	Dimensions						
			A	Ax	D	E ^①	F Flat, in.	Fx Flat, in.	U
<i>Dimensions, in.</i>									
1/4	1/8	-400-3TTR	2.12	1.06	0.60	0.16	1/2	9/16	0.68
	1/4	-400-3-4TTR	2.28	1.14					
3/8	1/4	-600-3TTR	2.40	1.20	0.66	0.23	5/8	3/4	0.90
1/2	3/8	-810-3TTR	2.84	1.42	0.90	0.31	13/16	7/8	1.04
	1/2	-810-3-8TTR	3.00	1.50					
5/8	1/2	-1010-3TTR	3.00	1.50	0.96	0.47	15/16	1 1/16	1.26
3/4	3/4	-1210-3TTR	3.14	1.57	0.96	0.62	1 1/16	1 3/8	1.62
	1/2	-1210-3-8TTR							
1	1	-1610-3TTR	3.86	1.93	1.23	0.78	1 3/8	1 5/8	1.91
<i>Dimensions, mm</i>									
6	1/8	-6M0-3TTR	53.9	27.0	15.3	4.0	1/2	9/16	17.3
	1/4	-6M0-3-4TTR	58.0	29.0					
8	1/8	-8M0-3TTR	57.7	28.8	16.2	4.0	9/16	9/16	17.3
	1/4	-8M0-3-4TTR	59.7	29.9					
10	1/4	-10M0-3TTR	67.0	33.5	17.2	5.9	13/16	3/4	22.9
12	3/8	-12M0-3TTR	72.0	36.0	22.8	7.9	13/16	7/8	26.4
	1/2	-12M0-3-8TTR	76.1	38.0					

Tees

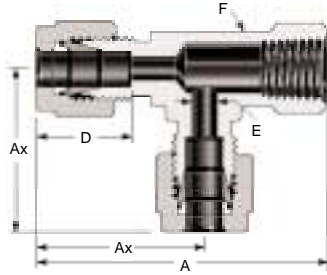

Tube ports are identical.

Female Run Tee—NPT Thread

Tube OD	NPT Female Pipe Size, in.	Basic Ordering Number	Dimensions				
			A	Ax	D	E	F Flat, in.
<i>Dimensions, in.</i>							
1/8	1/8	-200-3TFT	1.72	0.97	0.50	0.09	1/2
1/4	1/8	-400-3TFT	1.81	1.06	0.60	0.19	1/2
	1/4	-400-3-4TFT	2.05	1.17			11/16
3/8	1/4	-600-3TFT	2.11	1.23	0.66	0.28	11/16
1/2	3/8	-810-3TFT	2.30	1.42	0.90	0.41	13/16
	1/2	-810-3-8TFT	2.69	1.57			1 1/16
3/4	3/4	-1210-3TFT	3.01	1.76	0.96	0.62	1 3/8
1	3/4	-1610-3-12TFT	3.18	1.93	1.23	0.88	1 3/8
	1	-1610-3TFT	3.61	2.11			1 11/16
<i>Dimensions, mm</i>							
6	1/8	-6M0-3TFT	46.0	27.0	15.3	4.8	1/2
	1/4	-6M0-3-4TFT	52.1	29.8			11/16
8	1/8	-8M0-3TFT	48.9	29.9	16.2	6.4	5/8
	1/4	-8M0-3-4TFT	53.0	30.6			11/16
10	1/4	-10M0-3TFT	55.9	33.5	17.2	7.9	13/16
12	1/4	-12M0-3-4TFT	58.4	36.0	22.8	9.5	13/16
	3/8	-12M0-3TFT					10.3
16	1/2	-16M0-3TFT	68.2	39.8	24.4	12.7	1 1/16

Female Branch Tee—NPT Thread

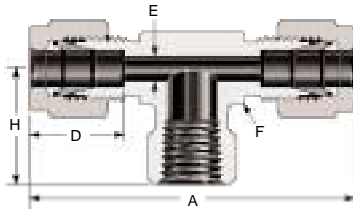

Tube OD	NPT Female Pipe Size, in.	Basic Ordering Number	Dimensions				
			A	D	E	F Flat, in.	H
<i>Dimensions, in.</i>							
1/8	1/8	-200-3TTF	1.94	0.50	0.09	1/2	0.75
1/4	1/8	-400-3TTF	2.12	0.60	0.19	1/2	0.75
	1/4	-400-3-4TTF	2.34				
3/8	1/4	-600-3TTF	2.46	0.66	0.28	11/16	0.88
	3/8	-600-3-6TTF	2.62				13/16
	1/2	-600-3-8TTF	2.84				1
1/2	1/4	-810-3-4TTF	2.84	0.90	0.41	13/16	0.88
	3/8	-810-3TTF	2.84				13/16
	1/2	-810-3-8TTF	3.06				1
5/8	1/2	-1010-3TTF	3.06	0.96	0.50	1	1.12
3/4	3/4	-1210-3TTF	3.52	0.96	0.62	1 3/8	1.25
1	3/4	-1610-3-12TTF	3.86	1.23	0.88	1 3/8	1.25
	1	-1610-3TTF	4.22				1 11/16
<i>Dimensions, mm</i>							
6	1/8	-6M0-3TTF	53.9	15.3	4.8	1/2	19.0
	1/4	-6M0-3-4TTF	59.5				22.4
8	1/8	-8M0-3TTF	59.7	16.2	6.4	5/8	19.0
	1/4	-8M0-3-4TTF	61.2				22.4
10	1/4	-10M0-3TTF	67.0	17.2	7.9	13/16	22.4
12	1/4	-12M0-3-4TTF	72.0	22.8	9.5	13/16	22.4
	3/8	-12M0-3TTF					
16	1/2	-16M0-3TTF	77.6	24.4	12.7	1	28.4

Union Cross

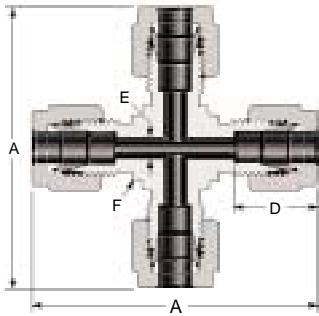

Tube OD	Basic Ordering Number	Dimensions			
		A	D	E	F Flat, in.
<i>Dimensions, in.</i>					
1/8	-200-4	1.76	0.50	0.09	3/8
1/4	-400-4	2.12	0.60	0.19	1/2
5/16	-500-4	2.34	0.64	0.25	5/8
3/8	-600-4	2.40	0.66	0.28	5/8
1/2	-810-4	2.84	0.90	0.41	13/16
3/4	-1210-4	3.14	0.96	0.62	1 1/16
1	-1610-4	3.86	1.23	0.88	1 3/8
<i>Dimensions, mm</i>					
3	-3M0-4	44.7	12.9	2.4	3/8
6	-6M0-4	53.9	15.3	4.8	1/2
8	-8M0-4	59.7	16.2	6.4	5/8
10	-10M0-4	67.0	17.2	7.9	13/16
12	-12M0-4	72.0	22.8	9.5	13/16
16	-16M0-4	74.0	24.4	12.7	15/16
18	-18M0-4	76.6	24.4	15.1	1 1/16
20	-20M0-4	89.3	26.0	15.9	1 3/8
25	-25M0-4	98.3	31.3	21.8	1 3/8

Tube Adapters



Solve Alignment Problems and Reduce Inventories

Swagelok tube adapters can help eliminate difficult alignment problems and reduce inventories. Swagelok tube adapters can be used with any Swagelok tube fittings in this catalog. So, stocking union elbows and union tees in various sizes and materials—along with commonly used Swagelok adapters—eliminates the need for stocking special elbows and tees.

Typical Alignment Problem

When installing pipe elbows or tees, it is often difficult to align the fitting with the desired run.

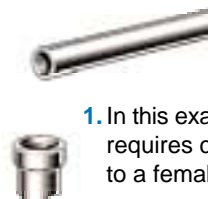

1. In this example, the installation requires connecting tubing to a female end connection.



2. When the pipe connection is tightened, the male elbow points in the wrong direction for the desired run. Loosening the pipe connection could mean leakage at the pipe thread.

Swagelok Solution

By using a Swagelok tube adapter in conjunction with a union elbow or tee, these difficulties can be avoided.

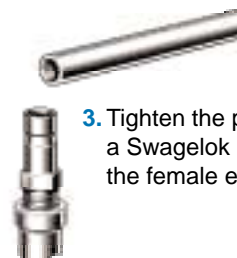

3. Tighten the pipe connection of a Swagelok male adapter into the female end connection.

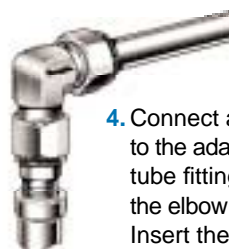

4. Connect a Swagelok union elbow or tee to the adapter by tightening the Swagelok tube fitting with a wrench, while holding the elbow or tee in the desired direction. Insert the tubing into the other end of the Swagelok elbow or tee and install the fitting.

⚠ Swagelok tube adapters are to be used ONLY in Swagelok tube fittings manufactured by Swagelok Company. Use in fittings made by other manufacturers may result in leakage or slippage.

Male Adapters

1 in. / 25 mm and under

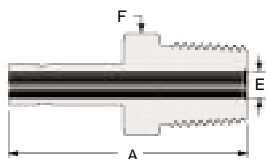

Over 1 in. / 25 mm

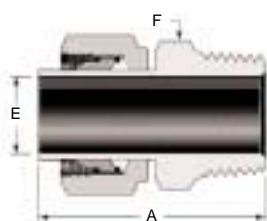

Male NPT Thread

Tube OD	NPT Male Pipe Size, in.	Basic Ordering Number	Dimensions		
			A	E ^②	F Flat
Dimensions, in.					
1/8	1/8 1/4	-2-TA-1-2 -2-TA-1-4	1.16 1.37	0.08	7/16 9/16
3/16	1/8 1/4	-3-TA-1-2 -3-TA-1-4	1.19 1.40	0.12	7/16 9/16
1/4	1/8 1/4 3/8 1/2	-4-TA-1-2 -4-TA-1-4 -4-TA-1-6 -4-TA-1-8	1.25 1.46 1.49 1.71	0.17	7/16 9/16 11/16 7/8
5/16	1/8 1/4	-5-TA-1-2 -5-TA-1-4	1.29 1.50	0.19 0.22	7/16 9/16
3/8	1/8 1/4 3/8 1/2	-6-TA-1-2 -6-TA-1-4 -6-TA-1-6 -6-TA-1-8	1.32 1.53 1.56 1.78	0.19 0.27 0.27 0.27	7/16 9/16 11/16 7/8
1/2	1/4 3/8 1/2	-8-TA-1-4 -8-TA-1-6 -8-TA-1-8	1.75 1.78 2.00	0.28 0.37 0.37	9/16 11/16 7/8
5/8	1/2	-10-TA-1-8	2.06	0.47	7/8
3/4	1/2 3/4	-12-TA-1-8 -12-TA-1-12	2.06	0.47 0.58	7/8 1 1/16
1	3/4 1	-16-TA-1-12 -16-TA-1-16	2.31 2.60	0.62 0.80	1 1/16 1 3/8
1 1/4	1 1/4	-20-TA-1-20 ^①	3.16	1.02	1 3/4
1 1/2	1 1/2	-24-TA-1-24 ^①	3.72	1.25	2 1/8
2	2	-32-TA-1-32 ^①	4.70	1.72	2 3/4
Dimensions, mm					
6	1/8 1/4	-6-MTA-1-2 -6-MTA-1-4	32.8 38.1	4.1	12 14
8	1/4	-8-MTA-1-4	39.1	5.6	14
10	1/4 3/8 1/2	-10-MTA-1-4 -10-MTA-1-6 -10-MTA-1-8	39.9 40.6 46.2	7.1	14 18 22
12	1/4 1/2	-12-MTA-1-4 -12-MTA-1-8	46.5 52.1	7.1 8.8	16 22
28	1 1 1/4	-28-MTA-1-16 ^① -28-MTA-1-20 ^①	74.7 76.2	22.2 22.5	35 46
30	1 1 1/4	-30-MTA-1-16 ^① -30-MTA-1-20 ^①	79.2 80.0	22.2 24.3	41 46
32	1 1/4	-32-MTA-1-20 ^①	81.0	26.5	46
38	1 1/2	-38-MTA-1-24 ^①	92.2	31.6	55

① Furnished with nut and preswaged ferrules.

② The E dimension is the minimum nominal opening. These fittings may have a larger opening at the pipe/straight thread end.

Male Adapters

1 in. / 25 mm and under

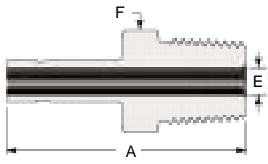

Over 1 in. / 25 mm

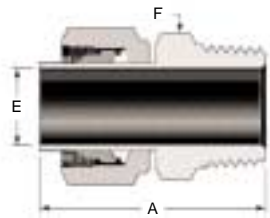

- ① Furnished with nut and preswaged ferrules.
- ② The E dimension is the minimum nominal opening. These fittings may have a larger opening at the pipe/straight thread end.

Male ISO Tapered Thread (RT)

Tube OD	ISO Male Pipe Size, in.	Basic Ordering Number	Dimensions		
			A	E ^②	F Flat
Dimensions, in.					
1/8	1/8	-2-TA-1-2RT	1.16	0.08	7/16
	1/4	-2-TA-1-4RT	1.37		9/16
1/4	1/8	-4-TA-1-2RT	1.25	0.17	7/16
	1/4	-4-TA-1-4RT	1.46		9/16
3/8	1/4	-6-TA-1-4RT	1.53	0.27	9/16
	3/8	-6-TA-1-6RT	1.56		11/16
	1/2	-6-TA-1-8RT	1.78		7/8
1/2	1/4	-8-TA-1-4RT	1.75	0.28	9/16
	3/8	-8-TA-1-6RT	1.78		11/16
	1/2	-8-TA-1-8RT	2.00		7/8
3/4	3/4	-12-TA-1-12RT	2.06	0.58	1 1/16
1	1	-16-TA-1-16RT	2.60	0.80	1 3/8
Dimensions, mm					
6	1/8	-6-MTA-1-2RT	32.8	4.1	12
	1/4	-6-MTA-1-4RT	38.1		14
8	1/4	-8-MTA-1-4RT	39.1	5.6	14
10	1/4	-10-MTA-1-4RT	39.9	7.1	14
	3/8	-10-MTA-1-6RT	40.6		18
12	1/4	-12-MTA-1-4RT	46.5	8.8	16
	3/8	-12-MTA-1-6RT	46.2		18
	1/2	-12-MTA-1-8RT	51.8		22
28	1	-28-MTA-1-16RT ^①	74.7	22.2	35
	1 1/4	-28-MTA-1-20RT ^①	76.2		46
30	1 1/4	-30-MTA-1-20RT ^①	80.0	24.3	46
32	1 1/4	-32-MTA-1-20RT ^①	81.0	26.5	
38	1 1/2	-38-MTA-1-24RT ^①	92.2	31.6	55

Male ISO Parallel Thread (RS)

1 in. / 25 mm and under

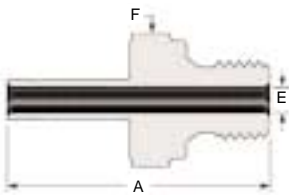

Over 1 in. / 25 mm

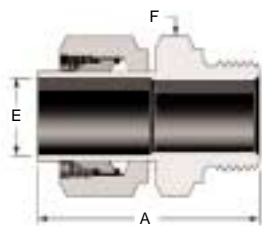

- ISO parallel gaskets are available. See page 48.
- ① Furnished with nut and preswaged ferrules.
- ② The E dimension is the minimum nominal opening. These fittings may have a larger opening at the pipe/straight thread end.

Tube OD	ISO Male Pipe Size, in.	Basic Ordering Number	Dimensions		
			A	E ^②	F Flat
Dimensions, in.					
1/8	1/8	-2-TA-1-2RS	1.25	0.08	9/16
	1/4	-2-TA-1-4RS	1.43		3/4
1/4	1/8	-4-TA-1-2RS	1.35	0.16	9/16
	1/4	-4-TA-1-4RS	1.53		3/4
3/8	1/4	-6-TA-1-4RS	1.59	0.23	3/4
	3/8	-6-TA-1-6RS	1.62		7/8
1/2	1/4	-8-TA-1-4RS	1.85	0.23	3/4
	3/8	-8-TA-1-6RS	1.88		7/8
	1/2	-8-TA-1-8RS	1.96		1 1/16
3/4	3/4	-12-TA-1-12RS	2.20	0.58	1 5/16
1	1	-16-TA-1-16RS	2.59	0.80	1 5/8
Dimensions, mm					
6	1/8	-6-MTA-1-2RS	34.3	4.0	14
	1/4	-6-MTA-1-4RS	38.9		19
8	1/4	-8-MTA-1-4RS	39.6	5.6	19
10	1/4	-10-MTA-1-4RS	40.4	7.1	19
	3/8	-10-MTA-1-6RS	41.1		22
	1/2	-10-MTA-1-8RS	43.2		27
12	1/4	-12-MTA-1-4RS	47.0	8.8	19
	3/8	-12-MTA-1-6RS	47.8		22
	1/2	-12-MTA-1-8RS	49.8		27
18	1/2	-18-MTA-1-8RS	51.3	11.9	27
	3/4	-18-MTA-1-12RS	55.9		35
28	1	-28-MTA-1-16RS ^①	71.9	19.8	41
	1 1/4	-28-MTA-1-20RS ^①	75.4		50
30	1 1/4	-30-MTA-1-20RS ^①	79.8	24.3	50
32	1 1/4	-32-MTA-1-20RS ^①	80.8	26.5	50
38	1 1/2	-38-MTA-1-24RS ^①	91.9	31.6	55

Male Adapters

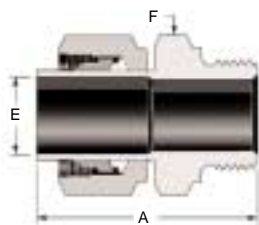

- ① Furnished with nut and preswaged ferrules.
- ② The E dimension is the minimum nominal opening. These fittings may have a larger opening at the pipe/straight thread end.

Male ISO Parallel Thread (RP)

Tube OD	ISO Male Pipe Size, in.	Basic Ordering Number	Dimensions		
			A	E ^②	F Flat
<i>Dimensions, mm</i>					
28	1 1 1/4	-28-MTA-1-16RP ^①	72.7	19.8	41
		-28-MTA-1-20RP ^①	77.3	22.5	50
30	1 1/4	-30-MTA-1-20RP ^①	81.1	24.3	50
32	1 1/4	-32-MTA-1-20RP ^①	82.1	26.5	50
38	1 1/2	-38-MTA-1-24RP ^①	94.5	31.8	55

Male SAE/MS Straight Thread

1 in. / 25 mm and under

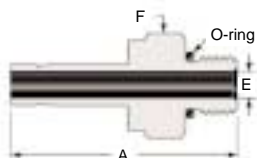

Over 1 in. / 25 mm

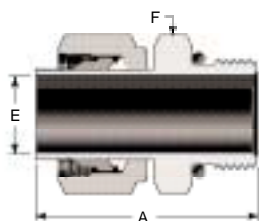

Adapts to SAE J1926 straight thread boss and SAE J1926/1 boss.

- ① Furnished with nut and preswaged ferrules.
- ② The E dimension is the minimum nominal opening. These fittings may have a larger opening at the pipe/straight thread end.

Tube OD	SAE/MS Thread Pipe Size	Basic Ordering Number	Dimensions		
			A	E ^②	F Flat
<i>Dimensions, in.</i>					
1/8	5/16-24	-2-TA-1-2ST	1.20	0.08	7/16
1/4	7/16-20	-4-TA-1-4ST	1.39	0.17	9/16
3/8	7/16-20 9/16-18 3/4-16	-6-TA-1-4ST	1.46	0.20	9/16
		-6-TA-1-6ST -6-TA-1-8ST	1.52 1.60	0.27 0.27	11/16 7/8
1/2	9/16-18 3/4-16	-8-TA-1-6ST	1.74	0.28	11/16
		-8-TA-1-8ST	1.82	0.37	7/8
5/8	7/8-14	-10-TA-1-10ST	1.94	0.47	1
3/4	1 1/16-12	-12-TA-1-12ST	2.10	0.58	1 1/4
1	1 5/16-12	-16-TA-1-16ST	2.41	0.80	1 1/2
1 1/4	1 5/8-12	-20-TA-1-20ST ^①	2.81	1.02	1 7/8
1 1/2	1 7/8-12	-24-TA-1-24ST ^①	3.28	1.25	2 1/8
2	2 1/2-12	-32-TA-1-32ST ^①	4.23	1.72	2 3/4

Male O-Seal Fitting (SAE/MS Straight Thread)

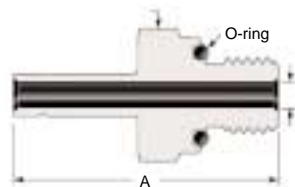

NOTE: See page 18 for mounting dimensions.

Tube OD	Thread Size	Basic Ordering Number	Dimensions		
			A	E	F Flat
<i>Dimensions, in.</i>					
1/8	5/16-24	-2-TA-1-OR	1.28	0.08	9/16
3/16	3/8-24	-3-TA-1-OR	1.38	0.12	5/8
1/4	7/16-20	-4-TA-1-OR	1.54	0.17	3/4
5/16	1/2-20	-5-TA-1-OR	1.64	0.22	7/8
3/8	9/16-18	-6-TA-1-OR	1.70	0.27	15/16
1/2	3/4-16	-8-TA-1-OR	1.95	0.37	1 1/8

Male Adapters

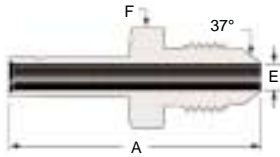

① The E dimension is the minimum nominal opening. These fittings may have a larger opening at the pipe/straight thread end.

Male AN Thread

Tube OD	AN Tube Flare Size	Thread Size	Basic Ordering Number	Dimensions		
				A	E ^①	F Flat
<i>Dimensions, in.</i>						
1/4	1/4	7/16-20UNJF-3	-4-TA-1-4AN	1.46	0.17	1/2
3/8	1/4 3/8	7/16-20UNJF-3	-6-TA-1-4AN	1.53	0.17	1/2
		9/16-18UNJF-3	-6-TA-1-6AN	1.56	0.27	5/8
1/2	1/2	3/4-16UNJF-3	-8-TA-1-8AN	1.91	0.37	13/16
3/4	3/4	1 1/16-12UNJ-3	-12-TA-1-12AN	2.21	0.58	1 1/8
1	1	1 5/16-12UNJ-3	-16-TA-1-16AN	2.58	0.80	1 3/8

Male Pipe Weld Adapter

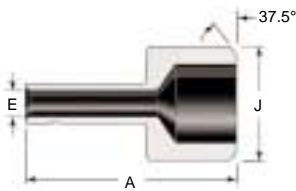

Tube OD	Male Pipe Weld Size	Basic Ordering Number	Dimensions		
			A	E	J
<i>Dimensions, in.</i>					
1/4	1/4	-4-TA-1-4W	1.14	0.17	0.540
3/8	1/2	-6-TA-1-8W	1.46	0.27	0.840
1/2	1/2	-8-TA-1-8W	1.66	0.37	0.840
	3/4	-8-TA-1-12W	1.68		1.050
3/4	3/4	-12-TA-1-12W	1.87	0.58	1.050

Female Adapters

1 in. / 25 mm and under



Over 1 in. / 25 mm

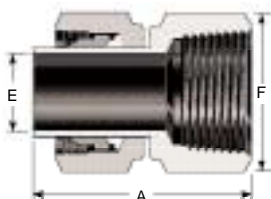

① Furnished with nut and preswaged ferrules.

Female NPT Thread

Tube OD	NPT Female Pipe Size, in.	Basic Ordering Number	Dimensions		
			A	E	F Flat
Dimensions, in.					
1/8	1/8 1/4	-2-TA-7-2 -2-TA-7-4	1.24 1.39	0.08	9/16 3/4
3/16	1/4	-3-TA-7-4	1.41	0.12	3/4
1/4	1/8	-4-TA-7-2	1.30	0.17	9/16
	1/4	-4-TA-7-4	1.46		3/4
	3/8	-4-TA-7-6	1.55		7/8
	1/2	-4-TA-7-8	1.79		1 1/16
5/16	1/4	-5-TA-7-4	1.48	0.22	3/4
3/8	1/8	-6-TA-7-2	1.35	0.27	9/16
	1/4	-6-TA-7-4	1.50		3/4
	3/8	-6-TA-7-6	1.59		7/8
	1/2	-6-TA-7-8	1.84		1 1/16
1/2	1/4	-8-TA-7-4	1.71	0.37	3/4
	3/8	-8-TA-7-6	1.79		7/8
	1/2	-8-TA-7-8	2.05		1 1/16
5/8	1/2	-10-TA-7-8	2.09	0.47	1 1/16
3/4	1/2	-12-TA-7-8	2.08	0.58	1 1/16
	3/4	-12-TA-7-12	2.16		1 5/16
	1	-12-TA-7-16	2.30		1 5/8
1	3/4	-16-TA-7-12	2.39	0.80	1 5/16
	1	-16-TA-7-16	2.53		1 5/8
1 1/4	1 1/4	-20-TA-7-20 ^①	3.06	1.02	2 1/8
1 1/2	1 1/2	-24-TA-7-24 ^①	3.50	1.25	2 3/8
		-32-TA-7-32 ^①	4.23		
Dimensions, mm					
6	1/8	-6-MTA-7-2	32.5	4.1	14
	1/4	-6-MTA-7-4	37.1		19
8	1/4	-8-MTA-7-4	37.6	5.6	19
10	1/4	-10-MTA-7-4	38.1	7.1	19
	3/8	-10-MTA-7-6	40.1		22
	1/2	-10-MTA-7-8	46.7		27
12	1/4	-12-MTA-7-4	43.7	8.8	19
	1/2	-12-MTA-7-8	52.3		27

Female ISO Tapered Thread (RT)

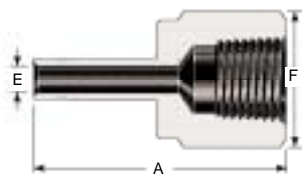

Tube OD	ISO Female Pipe Size, in.	Basic Ordering Number	Dimensions		
			A	E	F Flat
Dimensions, in.					
1/4	1/8	-4-TA-7-2RT	1.30	0.17	9/16
	1/4	-4-TA-7-4RT	1.45		3/4
3/8	1/4	-6-TA-7-4RT	1.50	0.27	3/4
	3/8	-6-TA-7-6RT	1.59		7/8
1/2	1/4	-8-TA-7-4RT	1.71	0.37	3/4
	3/8	-8-TA-7-6RT	1.80		7/8
	1/2	-8-TA-7-8RT	2.05		1 1/16
Dimensions, mm					
6	1/8	-6-MTA-7-2RT	33.0	4.1	14
10	1/4	-10-MTA-7-4RT	38.1	7.1	19

Female Adapters

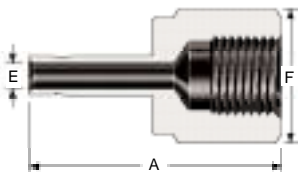

ISO parallel gaskets and O-rings are available. See pages 48 and 49.

Female ISO Parallel Thread (RP)

Tube OD	ISO Female Pipe Size, in.	Basic Ordering Number	Dimensions		
			A	E	F Flat
<i>Dimensions, in.</i>					
1/8	1/8	-2-TA-7-2RP	1.17	0.08	9/16
1/4	1/8	-4-TA-7-2RP	1.25	0.17	9/16
	1/4	-4-TA-7-4RP	1.50		3/4
3/8	1/4	-6-TA-7-4RP	1.55	0.27	3/4
	3/8	-6-TA-7-6RP	1.57		15/16
1/2	3/8	-8-TA-7-6RP	1.78	0.38	15/16
	1/2	-8-TA-7-8RP	2.02		1 1/16
<i>Dimensions, mm</i>					
6	1/8	-6-MTA-7-2RP	32.0	4.1	14
	1/4	-6-MTA-7-4RP	37.8		19

Female ISO Parallel (Gauge) Thread (RG)

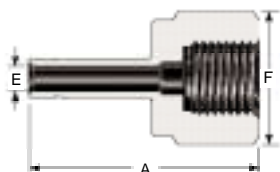

ISO parallel gaskets and O-rings are available. See pages 48 and 49.

Tube OD	ISO Female Pipe Size, in.	Basic Ordering Number	Dimensions		
			A	E	F Flat
<i>Dimensions, in.</i>					
1/4	1/4	-4-TA-7-4RG	1.39	0.17	3/4
3/8	3/8	-6-TA-7-6RG	1.55	0.26	15/16
1/2	1/2	-8-TA-7-8RG	1.80	0.28	1 1/16
<i>Dimensions, mm</i>					
6	1/4	-6-MTA-7-4RG	35.3	4.1	19
	3/8	-6-MTA-7-6RG	38.4		24
	1/2	-6-MTA-7-8RG	42.9		27
8	1/4	-8-MTA-7-4RG	33.0	5.5	19
	1/2	-8-MTA-7-8RG	43.7	5.6	27
10	1/4	-10-MTA-7-4RG	34.5	5.5	19
	1/2	-10-MTA-7-8RG	41.1	7.1	27
12	1/4	-12-MTA-7-4RG	40.1	5.5	19
	1/2	-12-MTA-7-8RG	48.8	7.0	27
16	1/2	-16-MTA-7-8RG	49.0	7.0	27
18	1/2	-18-MTA-7-8RG	49.3		

Female AN Thread

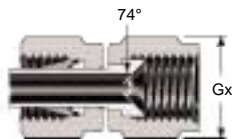

Tube OD	AN Tube Flare Size	Basic Ordering Number	Dimensions
			Gx Flat
<i>Dimensions, in.</i>			
1/8	1/8	-200-A-2ANF	3/8
	1/4	-200-A-4ANF	9/16
1/4	1/4	-400-A-4ANF	9/16
3/8	3/8	-600-A-6ANF	11/16
1/2	1/2	-810-A-8ANF	7/8

Nuts

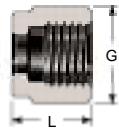

Female Nut

Tube OD	Basic Ordering Number	Dimensions	
		G	L
<i>Dimensions, in.</i>			
1/16	-102-1	5/16	0.31
1/8	-202-1	7/16	0.47
3/16	-302-1	1/2	0.47
1/4	-402-1	9/16	0.50
5/16	-502-1	5/8	0.53
3/8	-602-1	11/16	0.56
1/2	-812-1	7/8	0.69
5/8	-1012-1	1	0.69
3/4	-1212-1	1 1/8	0.69
7/8	-1412-1	1 1/4	0.69
1	-1612-1	1 1/2	0.81
1 1/4	-2002-1	1 7/8	1.25
1 1/2	-2402-1	2 1/4	1.50
2	-3202-1	3	2.06

Tube OD	Basic Ordering Number	Dimensions	
		G	L
<i>Dimensions, mm</i>			
2	-2M2-1	12	11.9
3	-3M2-1	12	11.9
4	-4M2-1	12	11.9
6	-6M2-1	14	12.7
8	-8M2-1	16	13.5
10	-10M2-1	19	15.1
12	-12M2-1	22	17.4
14	-14M2-1	25	17.4
15	-15M2-1	25	17.4
16	-16M2-1	25	17.4
18	-18M2-1	30	17.4
20	-20M2-1	32	17.4
22	-22M2-1	32	17.4
25	-25M2-1	38	20.6
28	-28M2-1	46	30.6
30	-30M2-1	50	32.7
32	-32M2-1	50	34.4
38	-38M2-1	60	40.6
50	-50M2-1	3 in.	52.3

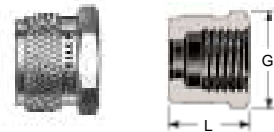

Knurled Nut

The Swagelok knurled nut tube fitting provides a leak-tight seal without the use of inserts on most wall thicknesses of polyethylene tubing. Inserts may be required for larger sizes.

To set the ferrules on the tubing, initial connections must be made with a wrench, tightening the nut 1 1/4 turns from finger-tight (3/4 turn for 1/16, 1/8 and 3/16 in.; 2, 3, and 4 mm fittings). Leak-tight connections may be *reassembled* with finger-tight assembly.

To order a knurled nut, add **K** as a suffix to the female nut's basic ordering number.

Example: B-402-1**K**

To order a knurled nut on an assembled fitting *with nylon ferrules*, add **KN** as a suffix to the fitting ordering number.

Example: SS-400-1-2**KN**

To order a knurled nut on an assembled fitting *with PTFE ferrules*, add **KT** as a suffix to the fitting ordering number.

Example: SS-400-1-2**KT**

Male Nut

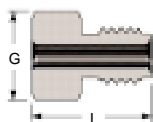

Tube OD	Basic Ordering Number	Dimensions	
		G	L
<i>Dimensions, in.</i>			
1/16	-1F2-1GC	1/4	0.38
1/8	-2F2-1GC	3/8	0.53
1/4	-4F2-1	1/2	0.62
1/2	-8F2-1	15/16	0.87

Tube OD	Basic Ordering Number	Dimensions	
		G	L
<i>Dimensions, mm</i>			
10	-10MF2-1	22	22.1
12	-12MF2-1	24	

For use in female Swagelok ports.

Nut-Ferrule Set/ Ferrule Set



Use of Nuts and Ferrules

Using Swagelok nuts and ferrules on tube fittings or valves with tube end connections requires critical interaction of precision parts.

Swagelok nuts and ferrules are sold as replacement parts for use with only Swagelok bodies, fittings, valves, and hose products.

Nut-Ferrule Set

Nut-Ferrule Set contains one nut, one back ferrule, and one front ferrule.

To order a Nut-Ferrule Set, add a material designator as a prefix.

Example: **SS-400-NFSET**

Tube OD	Basic Ordering Number
<i>Dimensions, in.</i>	
1/4	-400-NFSET
3/8	-600-NFSET
1/2	-810-NFSET

Ferrule Set

Ferrule Set contains one front ferrule and one back ferrule.

To order a Ferrule Set, add a material designator as a prefix to the basic ordering number.

Example: **SS-100-SET**

Tube OD	Basic Ordering Number
<i>Dimensions, in.</i>	
1/16	-100-SET
1/8	-200-SET
3/16	-300-SET
1/4	-400-SET
5/16	-500-SET
3/8	-600-SET
1/2	-810-SET
<i>Dimensions, mm</i>	
6	-6M0-SET
8	-8M0-SET
10	-10M0-SET
12	-12M0-SET

Sets are shown with arbors. One arbor holds five Nut-Ferrule Sets or ten Ferrule Sets.

Nut-Ferrule Package



Material	Designator
316 stainless steel	SS
Brass	B
Steel	S

Ferrule-Pak™ Package

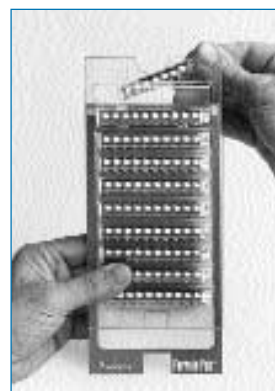

Material	Designator
316 stainless steel	SS
Alloy 400/R-405	M
Aluminum	A
Brass	B
Carbon steel	S
Nylon	NY
PTFE	T

To order Nut-Ferrule Package (50 nut-ferrule sets) or Ferrule-Pak Package (100 front and back sets), contact your independent Swagelok sales and service representative.

Ferrules



① Over 1 in. and over 25 mm stainless steel ferrules are PFA coated. To order silver-plated front ferrules, add **-BL** as a suffix to the basic ordering number.

Front Ferrule

Tube OD	Basic Ordering Number
<i>Dimensions, in.</i>	
1/16	-103-1
1/8	-203-1
3/16	-303-1
1/4	-403-1
5/16	-503-1
3/8	-603-1
1/2	-813-1
5/8	-1013-1
3/4	-1213-1
7/8	-1413-1
1	-1613-1
1 1/4	-2003-1 ^①
1 1/2	-2403-1 ^①
2	-3203-1 ^①

Tube OD	Basic Ordering Number
<i>Dimensions, mm</i>	
2	-2M3-1
3	-3M3-1
4	-4M3-1
6	-6M3-1
8	-8M3-1
10	-10M3-1
12	-12M3-1
14	-14M3-1
15	-15M3-1
16	-16M3-1
18	-18M3-1
20	-20M3-1
22	-22M3-1
25	-25M3-1
28	-28M3-1 ^①
30	-30M3-1 ^①
32	-32M3-1 ^①
38	-38M3-1 ^①
50	-50M3-1 ^①

Back Ferrule



② Over 1 in. and over 25 mm stainless steel ferrules are PFA coated. To order back ferrules without PFA coating, add **-WC** as a suffix to the basic ordering number.

Tube OD	Basic Ordering Number
<i>Dimensions, in.</i>	
1/16	-104-1
1/8	-204-1
3/16	-304-1
1/4	-404-1
5/16	-504-1
3/8	-604-1
1/2	-814-1
5/8	-1014-1
3/4	-1214-1
7/8	-1414-1
1	-1614-1
1 1/4	-2004-1 ^②
1 1/2	-2404-1 ^②
2	-3204-1 ^②

Tube OD	Basic Ordering Number
<i>Dimensions, mm</i>	
2	-2M4-1
3	-3M4-1
4	-4M4-1
6	-6M4-1
8	-8M4-1
10	-10M4-1
12	-12M4-1
14	-14M4-1
15	-15M4-1
16	-16M4-1
18	-18M4-1
20	-20M4-1
22	-22M4-1
25	-25M4-1
28	-28M4-1 ^②
30	-30M4-1 ^②
32	-32M4-1 ^②
38	-38M4-1 ^②
50	-50M4-1 ^②

ISO Parallel Gaskets



① Also available with fluorocarbon FKM inner ring bonded to a stainless steel outer ring. To order, use **SS** instead of **S** as a prefix to the basic ordering number. Example: **SS-8-RS-2V**

RS Fitting Steel Gasket

The RS fitting steel gasket provides a seal with male BSP/ISO parallel threads. The gasket consists of a fluorocarbon FKM or Buna inner ring bonded to a carbon steel outer ring. To order, add **V** for fluorocarbon FKM or **B** for Buna as a suffix to the basic ordering number. Example: S-2-RS-2**B**

Note: For use only with Swagelok RS fittings.



ISO Pipe Size	Basic Ordering Number	Dimensions		
		E	H	Tx
<i>Dimensions, in.</i>				
1/8	S-2-RS-2	0.41	0.08	0.63
1/4	S-4-RS-2 ^①	0.54		0.81
3/8	S-6-RS-2 ^①	0.68	0.10	0.94
1/2	S-8-RS-2 ^①	0.85		1.13
3/4	S-12-RS-2	1.06		1.38
1	S-16-RS-2	1.33		1.69

RP Fitting Copper Gasket

The RP fitting copper gasket provides a seal with male BSP/ISO parallel threads. Note: The RP gasket may be used with a Swagelok RS fitting.

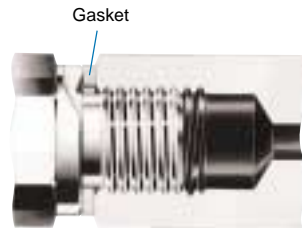

ISO Pipe Size	Ordering Number	Dimensions		
		E	H	Tx
<i>Dimensions, in.</i>				
1/8	CU-2-RP-2	0.39	0.04	0.59
1/4	CU-4-RP-2	0.52	0.06	0.75
3/8	CU-6-RP-2	0.66		0.91
1/2	CU-8-RP-2	0.83	0.08	1.06
3/4	CU-12-RP-2	1.05		1.30
1	CU-16-RP-2	1.31		1.58

RG Fitting Copper Gasket

The RG fitting copper gasket provides a seal on pressure gauges equipped with BSP/ISO parallel male threads.

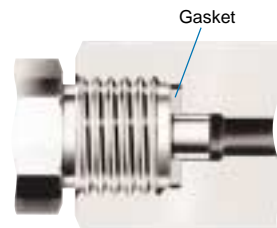

ISO Pipe Size	Ordering Number	Dimensions		
		E	H	Tx
<i>Dimensions, in.</i>				
1/4	CU-4-RG-2	0.30	0.07	0.42
3/8	CU-6-RG-2	0.34	0.09	0.56
1/2	CU-8-RG-2	0.36	0.10	0.70

O-Rings

O-rings for Positionable Fittings with ISO Parallel Threads

Port Size, in.	Uniform Size Number	Ordering Number	Durometer
1/8	502 ^①	VI9-OR-0502	90
1/4	111	VI9-OR-0111	
3/8	113	VI9-OR-0113	
1/2	508 ^①	VI9-OR-0508	
3/4	119	VI9-OR-0119	
1	217	VI9-OR-0217	

① Not a uniform O-ring size.

O-rings for Fittings with SAE/MS Straight Threads

Port Size, in.	Uniform Size Number	Ordering Number	Durometer
1/8	902	VI9-OR-0902	90
3/16	903	VI9-OR-0903	
1/4	904	VI9-OR-0904	
5/16	905	VI9-OR-0905	
3/8	906	VI9-OR-0906	
1/2	908	VI9-OR-0908	
5/8	910	VI9-OR-0910	
3/4	912	VI9-OR-0912	
7/8	914	VI9-OR-0914	
1	916	VI9-OR-0916	
1 1/4	920	VI9-OR-0920	
1 1/2	924	VI9-OR-0924	
2	932	VI9-OR-0932	

O-rings for Fittings with O-seal Straight Threads

Thread Size, in.	Uniform Size Number	Ordering Number	Durometer
5/16-24	011	BN7-OR-0011	70
3/8-24	012	BN7-OR-0012	
7/16-20	013	BN7-OR-0013	
1/2-20	112	BN7-OR-0112	
9/16-18	113	BN7-OR-0113	
3/4-16	116	BN7-OR-0116	
1 1/16-12	121	BN7-OR-0121	
1 5/16-12	125	BN7-OR-0125	

O-rings for Fittings with O-seal Pipe Threads

Thread Size, in.	Uniform Size Number	Ordering Number	Durometer
1/8	013	BN7-OR-0013	70
1/4	113	BN7-OR-0113	
3/8	116	BN7-OR-0116	
1/2	118	BN7-OR-0118	

Gap Inspection Gauges



Swagelok gap inspection gauges assure the installer or inspector that the fitting has been sufficiently pulled up on initial installation, whether using a multihead hydraulic swaging unit (MHSU) or air-actuated hydraulic swaging unit (AHSU), or wrench-tightening. All metal Swagelok tube fittings are gaugeable, with the exception of a few forged bodies in aluminum.

For Installation Using a Wrench

Fitting Size		Ordering Number
in.	mm	
Male Nut		
1/16	—	MS-IG-1F0
1/8	2, 3	MS-IG-2F0
Female Nut		
1/16	—	MS-IG-100
1/8	2, 3	MS-IG-200
3/16	4	MS-IG-300
1/4	6	MS-IG-400
1/4, 3/8, 1/2	6, 12	MS-IG-468
1/4, 1/2	6, 8, 10, 12	MS-IG-612M
5/16	8	MS-IG-500
3/8	—	MS-IG-600
—	10	MS-IG-10M0
1/2	12	MS-IG-810
5/8	14, 15, 16	MS-IG-1010
5/8 (SAF 2507)	—	MS-IG-2507-1010
3/4	18	MS-IG-1210
3/4 (SAF 2507)	—	MS-IG-2507-1210
7/8	20, 22	MS-IG-1410
1	25	MS-IG-1610

For Installation Using the AHSU

Fitting Size		Ordering Number
in.	mm	
Female Nut		
1/4, 3/8, 1/2	—	MS-AHSU-IG-468
—	6, 8, 10, 12	MS-AHSU-IG-612M

For Installation Using the MHSU

Fitting Size		Ordering Number
in.	mm	
Female Nut		
1/2 ^①	12	MS-MHSU-IG-810
5/8 ^②	14, 15, 16	MS-MHSU-IG-1010
5/8 (SAF 2507)	—	MS-MHSU-IG-2507-1010
3/4 ^②	18	MS-MHSU-IG-1210
3/4 (SAF 2507)	—	MS-MHSU-IG-2507-1210
7/8	20, 22	MS-MHSU-IG-1410
1	25	MS-MHSU-IG-1610-1
—	28	MS-MHSU-IG-28M0-1
	30	MS-MHSU-IG-30M0-1
1 1/4	—	MS-MHSU-IG-2000-1
—	32	MS-MHSU-IG-32M0-1
—	38	MS-MHSU-IG-38M0-1
1 1/2	—	MS-MHSU-IG-2400-1
—	50	MS-MHSU-IG-50M0-1
2	—	MS-MHSU-IG-3200-1

① The MHSU cannot be used for SAF 2507 tubing 1/2 in. and under.

② For 5/8 and 3/4 in. SAF 2507 tubing, order the 1 in. (25 mm) and over unit and SAF 2507 tooling and gauge.

Bulkhead Retainer

By using the bulkhead retainer, one person can tighten the jam nut on side A for initial bulkhead fitting installation. Now tubing can be connected to side A and B by one person with one wrench, since the bulkhead retainer acts as a backup wrench.

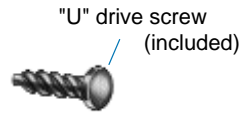
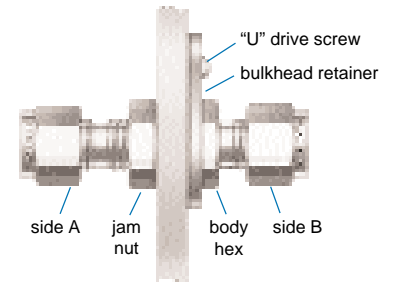

Bulkhead fitting installation utilizing bulkhead retainer

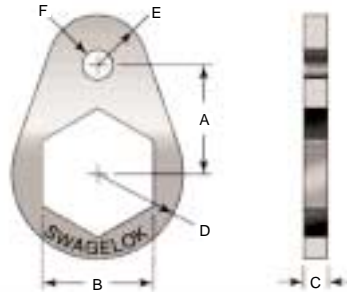

Fitting Size		Ordering Number	Dimensions, in.									
			A	B	C	D	E	F	"U" Drive Screw	Drill Number	Drill Hole Dia	
in.	mm											
1/16	—	SS-102-61F	3/8	5/16	1/8	5/16	5/32	5/32	5/32	#6-3/8	31	0.120
1/8	—	SS-202-61F	1/2	1/2	1/8	13/32	7/32	5/32	5/32	#6-3/8	31	0.120
3/16	3 and 4	SS-302-61F	9/16	9/16	1/8	15/32	1/4	5/32	5/32	#6-3/8	31	0.120
1/4	6	SS-402-61F	5/8	5/8	1/8	1/2	9/32	5/32	5/32	#6-3/8	31	0.120
5/16	—	SS-502-61F	11/16	11/16	1/8	9/16	5/16	5/32	5/32	#6-3/8	31	0.120
—	8	SS-8M2-61F	11/16	18 mm	1/8	9/16	5/16	5/32	5/32	#6-3/8	31	0.120
3/8	—	SS-602-61F	3/4	3/4	1/8	5/8	11/32	5/32	5/32	#6-3/8	31	0.120
—	10	SS-10M2-61F	15/16	22 mm	1/8	3/4	13/32	7/32	7/32	#10-1/2	27	0.144
1/2	12	SS-812-61F	15/16	15/16	1/8	3/4	13/32	7/32	7/32	#10-1/2	27	0.144
5/8	15 and 16	SS-1012-61F	1	1 1/16	1/8	13/16	13/32	7/32	7/32	#10-1/2	27	0.144
3/4	18	SS-1212-61F	1 1/16	1 3/16	1/8	29/32	15/32	7/32	7/32	#10-1/2	27	0.144
7/8	—	SS-1412-61F	1 1/8	1 5/16	1/8	1 1/32	17/32	7/32	7/32	#10-1/2	27	0.144
1	—	SS-1612-61F	1 9/32	1 5/8	1/8	1 5/32	9/16	7/32	7/32	#10-1/2	27	0.144

Preswaging Tool



For Swagelok tube fitting installations in close quarters, the Swagelok preswaging tool is a convenient accessory.

Fractional Tube Size in.	Ordering Number
Female Nut	
1/16	MS-ST-1F0
1/2	MS-ST-8F0
Male Nut	
1/16	MS-ST-100
1/8	MS-ST-200
3/16	MS-ST-300
1/4	MS-ST-400
5/16	MS-ST-500
3/8	MS-ST-600
1/2	MS-ST-810
5/8	MS-ST-1010
5/8 (SAF 2507)	MS-ST-2507-1010
3/4	MS-ST-1210
3/4 (SAF 2507)	MS-ST-2507-1210
7/8	MS-ST-1410
1	MS-ST-1610

Metric Tube Size mm	Ordering Number
Male Nut	
3	MS-ST-3M0
4	MS-ST-4M0
6	MS-ST-6M0
8	MS-ST-8M0
10	MS-ST-10M0
12	MS-ST-12M0
14	MS-ST-14M0
15	MS-ST-15M0
16	MS-ST-16M0
18	MS-ST-18M0
20	MS-ST-20M0
22	MS-ST-22M0
25	MS-ST-25M0

Insert for Swagelok Vinyl or Tygon® Tubing

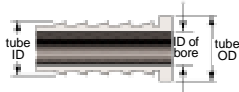

Swagelok inserts help secure soft plastic tubing being used with standard Swagelok tube fittings. In determining the correct size of the Swagelok insert to be used, always check outside diameter and inside diameter of the plastic tubing.

For a complete line of hose connectors for soft plastic tubing, see *Hose Connectors, Accessories, and Hose Adapters* in the Swagelok Product Binder.

Tube OD	Tube ID	ID of Bore	Basic Ordering Number
Dimensions, in.			
3/16	1/8	0.09	-305-2
1/4	1/8	0.09	-405-2
	0.17	0.11	-405-170
5/16	3/16	0.14	-405-3
	1/8	0.09	-505-2
	3/16	0.12	-505-3
3/8	1/4	0.19	-505-4
	3/16	0.12	-605-3
1/2	1/4	0.19	-605-4
	3/8	0.31	-815-4
5/8	1/2	0.31	-815-6
	3/8	0.31	-1015-6
3/4	1/2	0.44	-1015-8
	5/8	0.56	-1215-8
1	3/4	0.69	-1215-10
Dimensions, mm			
6	4	2.8	-1615-12
8	4	2.8	-6M5-4M
8	6	4.4	-8M5-6M
10	8	6.4	-10M5-8M
12	8	6.4	-12M5-8M
	10	8.3	-12M5-10M

Ordering Information

Add the insert material designator as a prefix to the basic ordering number.

Insert Material	Designator
Brass	B
Aluminum	A
Steel	S
Stainless steel	SS
Alloy 400/R-405	M
Nylon	NY

Example: **B-305-2**

Hydraulic Swaging Units

Multihead (MHSU)

- Preswages Swagelok ferrules onto tubing
- Provides Swagelok tube fitting connections that are 100 % gaugeable upon initial installation. Use MHSU gap inspection gauges supplied with the unit.
- Is available in two unit sizes, with a choice of interchangeable fractional or metric tooling for:
 - 1/2 to 1 in. and 12 to 25 mm tubing and tube adapters
 - 1 to 2 in. and 25 to 50 mm tubing and tube adapters
- Places no initial strain on nut or fitting body threads or on body seal surfaces
- **Must** be used to install 1 1/4, 1 1/2, and 2 in. and 28, 30, 32, 38, and 50 mm Swagelok tube fittings
- Is standard with a tube marking feature to indicate when tube is properly bottomed in the unit
- Is available with a support base
- Fits neatly in a rugged plastic carrying case
- Reduces assembly and installation time and operator error.



For additional information, see the *Swagelok Hydraulic Swaging Units—Multihead (MHSU)* catalog. For instructions, see *Multihead Hydraulic Swaging Unit (MHSU) Setup and Operation Instructions*.

Air-Actuated (AHSU)

- Preswages Swagelok ferrules onto tubing
- Provides Swagelok tube fitting connections that are 100 % gaugeable upon initial installation
- Requires only one unit with interchangeable tooling to install 1/4 to 1/2 in. and 6 to 12 mm Swagelok tube fitting ferrule sizes
- Places no initial strain on nut or fitting body threads or on body seal surfaces
- Requires no threading of nut on or off the tooling
- Fits neatly in a rugged plastic carrying case.
- Reduces assembly and installation time and operator error



For additional information, see the *Swagelok Hydraulic Swaging Units—Air-Actuated (AHSU)* catalog. For instructions, see *Air-Actuated Hydraulic Swaging Unit (AHSU) Setup and Operation Instructions*.

Swagelok Tube Fitting Instructions for 1 in. / 25 mm and Smaller Fittings

Fig. 1

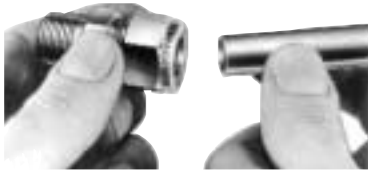

Fig. 2



Fig. 3



Installation Instructions

Note: These instructions apply to traditional fittings and fittings with the advanced back-ferrule geometry.

1. Insert tubing into the Swagelok tube fitting (Fig. 1).
2. Make sure that the tubing rests firmly on the shoulder of the tube fitting body and that the nut is finger-tight.
3. Scribe the nut at the 6 o'clock position (Fig. 2).
4. While holding fitting body steady, tighten the nut 1 1/4 turns to the 9 o'clock position. (Fig. 3)

Note: For 1/16, 1/8, and 3/16 in.; 2, 3, and 4 mm tube fittings, tighten the nut 3/4 turn to the 3 o'clock position.

Installation in High-Pressure Applications and High Safety-Factor Systems

1. Insert tubing into the Swagelok tube fitting.
2. Make sure that the tubing rests firmly on the shoulder of the tube fitting body.
3. Due to the variations of tubing diameters, a common starting point is desirable. Therefore, tighten the nut until the tubing will not turn by hand or move axially in the fitting.
4. Scribe the nut at the 6 o'clock position.
5. While holding fitting body steady, tighten the nut 1 1/4 turns to the 9 o'clock position.

Note: For 1/16, 1/8, and 3/16 in.; 2, 3, and 4 mm tube fittings, tighten the nut 3/4 turn to the 3 o'clock position.

Gaugeability

On initial installation, the Swagelok gap inspection gauge assures the installer or inspector that a fitting has been sufficiently tightened.

Position the Swagelok gap inspection gauge next to the gap between the nut and body.

- If the gauge will not enter the gap, the fitting is sufficiently tightened (Fig. 4).
- If the gauge will enter the gap, additional tightening is required (Fig. 5).

Fig. 4



Fig. 5



Fig. 6



Fig. 7



Fig. 8



Female pipe port
on existing equipment

Fig. 9



Reassembly Instructions

You may disassemble and reassemble a Swagelok tube fitting, port connector, cap, and plug many times.

1. Insert tubing with preswaged ferrules into the fitting body until the front ferrule seats (Fig. 6).
2. Rotate the nut with a wrench to the previously pulled-up position; at this point a significant increase in resistance will be encountered.
3. Tighten slightly with a wrench (Fig. 7).

Note: Do not use the gap inspection gauge with reassembled fittings.

Tube Adapters

Installation Instructions

1. Install the end opposite the tube adapter end (Fig. 8).
2. Insert the tube adapter into the Swagelok tube fitting. Make sure that the tube adapter rests firmly on the shoulder of the tube fitting body and that the nut is finger-tight (Fig. 9).
3. Scribe the nut at the 6 o'clock position.
4. While holding fitting body steady, tighten the nut 1 1/4 turns to the 9 o'clock position.

Note: For 1/8 and 3/16 in. tube fittings, tighten the nut 3/4 turn to the 3 o'clock position.

Fig. 10



Fig. 11



Fig. 12



Fig. 13



Fig. 14



Fig. 15



Port Connector

Installation Instructions—machined ferrule end

1. Remove the nut and ferrules from one Swagelok tube fitting end.
 2. Place the nut over the machined ferrule end of the port connector (Fig. 10).
 3. Turn the nut onto the fitting so that it is finger-tight (Fig. 11).
 4. Scribe the nut at the 6 o'clock position.
 5. While holding fitting body steady, tighten the nut 1/4 turn to the 9 o'clock position.
- Note: For 1/16 and 1/8 in. and 3 mm tube fittings, tighten the nut 1/8 turn.

Installation Instructions—tube adapter end

1. Insert the tube adapter into the Swagelok tube fitting. Make sure that the tube adapter rests firmly on the shoulder of the tube fitting body and that the nut is finger-tight (Fig. 12).
 2. Scribe the nut at the 6 o'clock position.
 3. While holding fitting body steady, tighten the nut 1 1/4 turns to the 9 o'clock position.
- Note: For 1/16 and 1/8 in. and 3 mm tube fittings, tighten the nut 3/4 turn to the 3 o'clock position.

Cap

Installation Instructions

See tube fitting installation instructions.

Plug

Installation Instructions

While holding fitting body steady, tighten the plug 1/4 turn from the finger-tight position.

Note: For 1/16, 1/8, and 3/16 in.; 2, 3, and 4 mm tube fittings, tighten the plug 1/8 turn. For over 1 in. and over 25 mm tube fittings, tighten the plug 1/4 turn.

Preswaging Tool

Installation Instructions

1. Install the Swagelok nut and ferrules onto the preswaging tool.
2. Insert tubing into the preswaging tool.
3. Make sure that the tubing rests firmly on the shoulder of the preswaging tool body and that the nut is finger-tight.
4. Scribe the nut at the 6 o'clock position.
5. While holding the preswaging tool steady, tighten the nut 1 1/4 turns to the 9 o'clock position.

Note: For 1/16, 1/8, and 3/16 in.; 2, 3, and 4 mm tube fittings, tighten the nut 3/4 turn to the 3 o'clock position (Fig. 13).

6. Loosen the nut.
7. Remove the tubing with preswaged ferrules from the preswaging tool.

Note: If the tubing sticks in the preswaging tool, remove the tubing by gently rocking it back and forth. Do not turn the tubing (Fig. 14).

8. Insert tubing with preswaged ferrules into the fitting body until the front ferrule seats.
9. Rotate the nut with a wrench to the previously pulled-up position; at this point, a significant increase in resistance will be encountered.

10. Tighten slightly with a wrench

Note: Do not use the gap inspection gauge with fittings that were assembled using the preswaging tool (Fig. 15).

Swagelok Tube Fittings

Installation Instructions for Fittings Larger Than 1 in. / 25 mm

1. Install using a hydraulic swaging unit.
2. Tighten nut 1/2 turn past finger-tight once ferrules are preswaged.

Weld Fittings

Welding Precautions for Swagelok Tube Fittings with Weld End Connections

1. Remove the nut and ferrules.
2. Turn a Swagelok tube fitting plug or another nut onto the fitting so that it is finger-tight. This protects the threads and sealing components.
3. Provide a suitable heat sink to dissipate the heat.
4. Tack weld at four positions 90° apart to hold the fitting in place and to ensure alignment and concentricity of the components.
5. Complete the weld.
6. Remove the plug or nut and replace the nut and ferrules.

⚠ CAUTION: When welding carbon steel fittings, the heat often removes the protective oil from the threads. It is important to apply another lubricant, such as Goop® thread lubricant.

Positionable Elbows and Tees

Installation Instructions

1. Turn the positionable end into the female fitting until the metal back-up washer contacts the face of the fitting.
2. Turn the positionable end out of the female fitting (not more than one turn) until the Swagelok tube fitting end is positioned properly.
3. While holding fitting body steady, tighten the lock nut until the metal back-up washer contacts the face of the fitting.

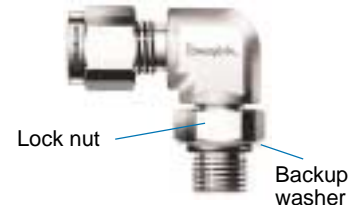

O-Seal Male Connectors

Installation Instructions

1. Turn the O-seal connector into the female end until it is finger-tight.
2. Tighten the O-seal connector until it makes metal-to-metal contact with the face of the female end.
3. Tighten slightly with a wrench.

The Swagelok Limited Lifetime Warranty

Swagelok hereby warrants to the purchaser of this Product that the non-electrical components of the Product shall be free from defects in material and workmanship for the life of the Product. All electrical components installed in or on the Product are warranted to be free from defects in material and workmanship for twelve months from the date of purchase.

The purchaser's remedies shall be limited to replacement and installation of any parts that fail through a defect in material or workmanship.

MANUFACTURER SPECIFICALLY DISAVOWS ANY OTHER REPRESENTATION, EXPRESS OR IMPLIED, WARRANTY, OR LIABILITY RELATING TO THE CONDITION OF USE OF THE PRODUCT, AND IN NO EVENT SHALL SWAGELOK BE LIABLE TO PURCHASER, OR ANY THIRD PARTY, FOR ANY DIRECT OR INDIRECT CONSEQUENTIAL OR INCIDENTAL DAMAGES.

Safe Product Selection

When selecting a product, the total system design must be considered to ensure safe, trouble-free performance. Function, material compatibility, adequate ratings, proper installation, operation, and maintenance are the responsibilities of the system designer and user.

Caution: Do not mix or interchange parts with those of other manufacturers.