

All-in-one touchscreen interface and logic controller

FT1A Touch

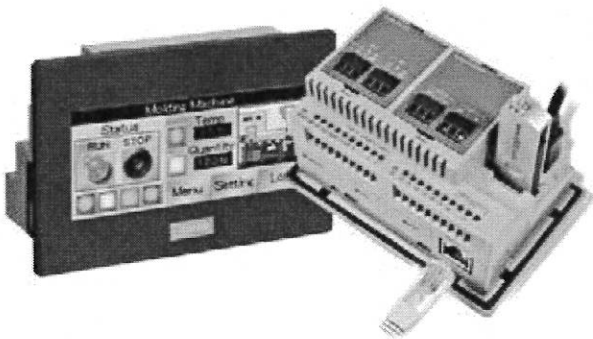

The FT1A SmartAXIS Touch combines operator interface and control in a single compact package, all programmable with IDEC's PC-based software. The FT1A Touch is available in 12 I/O and 14 I/O configurations with analog I/O expansion capability suitable for advanced analog monitoring and control.

KEY FEATURES

- 3.8" HMI+PLC
- Models with 12 or 14 I/O
- Embedded RJ45 Ethernet Port
- Modbus TCP or RTU
- Built-in 2 analog inputs
- Built-in 2 analog outputs
- Optional Analog Cartridges
- PID Controls
- USB Maintenance Port
- Seamless interface with other PLCs
- Class 1 Div. 2 Hazardous Locations
- -20 to 55 degree C operating temp.
- IP66f, Nema 4X (indoor), 13



General Specifications

Part No.	FT1A-12RA-*	FT1A-14KA-* / FT1A-14SA-*
Output	Relay output	Transistor output
Rated Power Voltage/ Power Supply Isolation	24V DC/Not isolated	
Allowable Voltage Range	20.4 to 28.8V DC (including ripple)	
Power Consumption	9.2 W maximum	11W maximum
Allowable Momentary Power Interruption	10 ms maximum	
Dielectric Strength	Between power terminal and FE terminal: 500V AC, 5 mA, 1 minute Between power terminal and output terminal: 2,300V AC, 5 mA, 1 minute	Between power terminal and FE terminal: 500V AC, 5 mA, 1 minute Between power terminal and output terminal: 500V AC, 5 mA, 1 minute
EMC Immunity	IEC/EN 61131-2:2007 compliant	
Inrush Current	50A maximum (5ms maximum)	
Operating Temperature	Color display: -20 to +55°C, Monochrome display: 0 to +55°C (Note 1) (Note 2)	
Storage Temperature	-20 to +60°C (no freezing)	
Relative Humidity	10 to 95% RH (no condensation)	
Pollution Degree	2 (IEC 60664-1)	
Corrosion Immunity	Atmosphere free from corrosive gases	
Degree of Protection	IP66F TYPE 4X TYPE 13 (Panel front) (Note 3), IP20 (Rear)	
Ground	Functional grounding	
Protective grounding conductor	UL1007 AWG16	
Vibration Resistance	5 to 8.4 Hz half amplitude 3.5 mm, 8.4 to 150 Hz, acceleration 9.8 m/s ² (1G), 2 hours per axis on each of three mutually perpendicular axis (IEC 61131-2)	
Shock Resistance	147 m/s ² , 11 ms, X, Y, Z directions 3 times (IEC 61131-2)	
Mounting Structure	Panel mount	
Weight (approx.)	300g	250g

Note 1: FT1A-12RA-* hardware version V130 (indicated on hardware) and earlier is UL, c-UL listed at 50°C (maximum operating temperature).

Note 2: See SmartAXIS Touch User's Manual FT9Y-B139Q(2) for I/O derating.

Note 3: Operation not guaranteed when used with certain types of oils.

Function Specifications

Part Number			FT1A-12RA-*	FT1A-14KA-*	FT1A-14SA-*
Control System			Stored program system		
Ladder Program	Instruction	Basic Instructions	42 types		
	Words	Advanced Instructions	98 types		
	Program Capacity		Program size: 47.4 kB, Configuration memory capacity: 5 MB		
	Processing Time	Basic Instruction	1850µs/1,000 steps		
		END Processing	5 msec minimum		
FB			37 types		
Program Capacity			Program size: 38kB, Configuration memory capacity: 5MB		
FBD	No. of FB	FB (Note 1)	1,000		
		Timer (T)	200		
		Counter (C)	200		
	Processing Time	Basic Instruction	4ms/100		
		END Processing	5ms minimum		
User Program Storage			Flash ROM (100,000 times)		
I/O Points	Inputs		8 (V3.90 or above: 90 max. can be added with remote I/O master function)		
	Outputs		8 (90 max. can be added with remote I/O master function)		
Analog Input			4 (V3.90 or above: 54 max. can be added with remote I/O master function)		
Analog Output			2 (V3.90 or above: 24 max. can be added with remote I/O master function)		
Internal Relays			—		
Shift Registers			2 (4 max. can be added with analog cartridge, and 24 max. can be added with remote master function)		
Data Registers			2 (4 max. can be added with analog cartridge)		
Special Data Registers			—		
Counters			1,024		
Timer (1ms, 10 ms, 100 ms, 1s)			128		
Clock			2000		
RAM Backup	Backup Data		Precision: ±30 seconds/month (25°C, typical)		
	Backup Duration		Internal relays, shift registers, counters, data registers, clock data		
	Battery		Approximately 30 days (typical) at 25°C after backup battery is fully charged		
	Charging Time		Lithium secondary battery		
	Replaceability		Approximately 15 hours required to charge from 0 to 90%		
Self-Diagnostic Functions			Not possible		
Input Filter			Keep data check, power failure check, watchdog timer check, timer/counter preset value change error check, user program syntax check, user program execution check		
Catch Input/Interrupt Input			No filter, 3 to 15 ms (selectable in increments of 1 ms)		
High-speed Counter	Maximum Counting Frequency and Points		4/4		
	Counting Range		1 (5 kHz, multiple 2/4, single-phase cannot be used)		
	Operation Mode		4 (x 10 kHz)		
	Built-in Points		0 to 4,294,967,295 (32 bits)		
Analog Voltage Inputs	Input Range	Rotary encoder mode and adding counter mode			
	Input Impedance	2			
	Digital Resolution	0 to 10V DC			
Number of Relay Outputs			0 to 10V DC (voltage input) / 4 to 20 mA (current input)		
Number of Transistor Outputs			78 kΩ (voltage input) / 250 Ω (current input)		
Analog Output	Built-in Points		0 to 1,000 (10 bits)		
	Output Range		10A relay: 4		
	Digital Resolution		—		
USB-mini B (Note 2)			4 (sink) 4 (source)		
USB-A (Note 2)			2		
RS232C (Note 2)			—		
RS485/422 (Note 2)			0 to 10V DC (voltage output) / 4 to 20 mA (current output)		
Ethernet			0 to 1,000 (10 bits)		
Expansion Communication Ports	Port 2		—		
	Port 3		—		
Memory Cartridge			—		
SD Memory Card			—		
Analog Cartridge Interface		Number of Ports	—		
		Connectable Cards	2		
			4 (FC6A-PJ2A, FC6A-PK2AV, FC6A-PK2AW, FC6A-PJ2CP)		

Note 1: Except for timer, counter, input FB, and output FB.
 Note 2: Not isolated from internal circuits.

Display Specifications

Part No.	Touch	
Display Element	TFT color LCD	STN monochrome LCD
Colors/Shades	65,536 colors	Monochrome 8 shades
Effective Display Area	88.92 W x 37.05 H mm	87.59 W x 35.49 H mm
Display Resolution	240 W x 100 H pixels	
View Angle	Left/right 40°, top 20°, bottom 60°	Left/right/top/bottom: 45°
Contrast Adjustment	Not possible	32 levels
Backlight	LED	LED (white, red, pink)
Backlight Life	50,000 hours (Note 1)	
Brightness	400 cd/m ² (Note 2)	740 cd/m ² (Note 2)
Brightness Adjustment	32 levels	
Backlight Control	Auto off function	
Backlight Replacement	Not possible	
Display Character Size	1/4 Size	8 x 8 pixels [JIS 8-bit code, ISO 8859-1 (Western European languages), ANSI 1250 (central Europe)], ANSI 1257 (Baltic), ANSI 1251 (Cyrillic)
	1/2 Size	8 x 16 pixels [JIS 8-bit code, ISO 8859-1 (Western European languages), ANSI 1250 (central Europe)], ANSI 1257 (Baltic), ANSI 1251 (Cyrillic)
		16 x 32 pixels, 24 x 48 pixels, 32 x 64 pixels (Western European languages: ISO 8859-1)
	Full Size	16 x 16 pixels (Japanese JIS first and second level characters, simplified Chinese, traditional Chinese, Korean)
Double Size	32 x 32 pixels (Japanese JIS first level characters, Mincho font)	
No. of Characters	1/4 Size	30 characters x 12 lines/screen
	1/2 Size	30 characters x 6 lines/screen
	Full Size	15 characters x 6 lines/screen
	Double Size	7 characters x 3 lines/screen
Character Magnification	0.5x, 1x, 2x, 3x, 4x, 5x, 6x, 7x, 8x vertically and horizontally	
Character Attributes	Blink, reverse, bold, shadowed (blink is 1 sec or 0.5 sec)	
Graphics	Line, polyline, polygon, rectangle, circle, ellipse, arc, pie, equilateral polygons (3, 4, 5, 6, 8), fill, picture	
Window Display	3 popup screens + 1 system screen	

Note 1: The backlight life refers to the time until the brightness reduces by half after use at 25°C.

Note 2: Brightness of LCD only (monochrome LCD: when lit white).

Operation Specifications

Part No.	Touch
Switching Element	Analog resistive membrane (touch panel)
Operating Force	0.2 to 2.5N
Mechanical Life	1 million operations
Acknowledgment Sound	Electric Buzzer
Multiple Press	Not possible

HMI Function Specifications

Functions	Drawings, bit button, word button, goto screen button, key button, multi-button, keypad, selector switch, potentiometer, numerical input, character input, pilot lamp, picture display, message display, message switching display, alarm list display, alarm log display, numerical display, bar chart, line chart, pie chart, meter, calendar, bit write command, word write command, goto screen command, timer, script command, multi-command, system area, start time, Auto Backlight OFF, O/I Link, user communication, maintenance communication, DM Link Communication, PLC Link Communication (Note 1), alarm log, data log, operation log, data storage area, preventive maintenance, recipe, text group, global script, user account, project data transfer using external memory, downloading logged data in external memory, USB auto-run function
------------------	-----------------------------------------------------------------------------------------------------------------------------------------------------------------------------------------------------------------------------------------------------------------------------------------------------------------------------------------------------------------------------------------------------------------------------------------------------------------------------------------------------------------------------------------------------------------------------------------------------------------------------------------------------------------------------------------------------------------------------------------------------------------------------------------------------------------------------------------------------------------

Note 1: The up-to-date information on the connectable PLC can be obtained from <http://www.idec.com/language>.

Input Specifications

Part Number		*12RA-*	*14KA-*	*14SA-*	
Digital Input	Input Points	6			
	Input Type	Sink	Source	Sink	
	Input Voltage Range	0 to 28.8V DC			
	Rated Input Current	4.4 mA	5.2 mA	4.4 mA	
	Input Impedance	5.5 kΩ	4.7 kΩ	5.5 kΩ	
	Input Delay Time	OFF → ON	2.5 μs + soft filter setting		
		ON → OFF	5 μs + soft filter setting		
	Isolation	Between input terminals	Not isolated		
		Internal circuit	Not isolated		
	Input Type	Type 1 (IEC 61131-2)			
	External Load for I/O Interconnection	Not needed			
	Operating Level	OFF voltage	Sink type: 5V DC max. Source type: 15V DC min.		
		ON voltage	Sink type: 15V DC min. Source type: 5V DC max.		
		OFF current	Sink type: 0.9 mA max. Source type: -1.0 mA min.		
ON current		Sink type: 2.7 mA min. Source type: -3.0 mA max.			
Input Points	2				
Input Type	Voltage input	Voltage/Current input			
Input Range	0 to 10.0 VDC	0 to 10.0 VDC / 4 to 20 mA			
Sampling Duration Time	2 ms maximum				
Total Input System Transfer Time	3 ms + sampling time + scan time	3 ms + sampling time + scan time (voltage input) 12 ms + sampling time + scan time (current input)			
Digital Resolution	0 to 1,000 (10 bits)				
Input Error	25°C	±3% of full scale			
	Total	±5% of full scale			
Isolation	Between input terminals	Not isolated			
	Internal circuit	Not isolated			
Digital I/O	Type 1 (not conforming to IEC 61131-2 digital I/O type)				
When used as digital input	OFF voltage	5V maximum			
	ON voltage	15V minimum			
	OFF current	0.06 mA maximum			
	ON current	0.20 mA minimum			
External Power for Input	Input Voltage Range	—			
	Output Current Capacity	—			

Output Specifications

Part Number		+12RA-*	+14KA-*	+14SA-*	
Transistor Output	Output Points	Transistor Sink Output	4	—	
		Transistor Source Output	—	4	
	Rated Load Voltage		24V DC		
	Input Voltage Range		20.4 to 28.8V DC		
	Maximum Load Current	1 point	0.3A maximum		
		1 common	1A maximum		
	Voltage Drop (ON Voltage)		1V maximum (voltage between COM and output terminals when output is ON)		
	Inrush Current		1A		
	Leakage Current		—		
	Clamping Voltage		39V ± 1V		
	Maximum Lamp Load		8 W maximum		
	Inductive Load		L/R = 10 ms (28.8V DC, 1 Hz)		
	External Current Draw		100 mA maximum, 24V DC		
	Isolation	Between output terminal and internal circuit		Photocoupler isolated	
Between output terminals		Not isolated			
Output Delay	OFF ON		100µs max.		
	ON OFF		200µs max.		
Relay Output Common	Electrical Life		100,000 operations minimum (resistive load 1,800 operations/h)		
	Mechanical Life		20 million operations minimum (no load 18,000 operations/h)		
	Dielectric Strength	Between output terminal and internal circuit		2,300V AC, 1 minute	
		Between output terminals (between COMs)		2,300V AC, 1 minute	
Analog Output	Output Points		2		
	Analog Output Signal Type		Voltage/Current output (Selectable)		
	Analog Output Range		0 to 10V DC / 4 to 20mA		
	Load Impedance		2kΩ min (voltage input) / 500 Ω max (current input)		
	Applicable Load Type		Resistive Load		
	Maximum Deviation at 25°C		±0.3% of full scale		
	Temperature Coefficient		±0.02%/°C of full scale		
	Repeatability After Stabilization Time		±0.4% of full scale		
	Non-linearity		±0.01% of full scale		
	Output Ripple		30mV max. (spike noise not included)		
	Overshoot		0% (Note 2)		
	Total Error		±1.0% of full scale including ripple		
	Effect of Improper Output Connection		No damage		
	Digital Resolution		0 to 1,000 (10 bits)		
	Output Value of LSB		10mV (0-10V) / 16µA (4-20mA)		
Monotonicity		Yes			
Current loop open		Not detectable			

Note 1: High-speed output terminal (100 kHz pulse output terminal): 5 µs max. Normal output terminal (including 5kHz pulse output terminal): 100 µs max.

Note 2: Overshoot may occur under light load conditions. Overshoot can be suppressed by inserting a damping resistor. Damping resistor value: approx. 150Ω including the input impedance.

Analog Expansion Cartridge Specifications (FC6A-P)

Specifications

Part No.	FC6A-PJ2A	FC6A-PJ2CP	FC6A-PK2AV	FC6A-PK2AW
Type	Voltage/Current Input	Temperature Input	Voltage Output	Current Output
Number of Input/Output	2	2	2	2
Rated Voltage	5.0V, 3.3V (supplied from the Touch)			
Consumption Current	5.0V: – 3.3V: 30mA		5.0V: 70mA 3.3V: 30mA	5.0V: 185mA 3.3V: 30mA
Weight	15g			

Output Specifications

Part Number		FC6A-PK2AV	FC6A-PK2AW
Type		Voltage Output	Current Output
Output Type	Voltage Output	0 to 10V DC	—
	Current Output	—	4 to 20mA DC
Load	Impedance	2kΩ min.	500 kΩ max.
	Load Type	Resistance Load	
D/A Conversion	Cycle Time	20ms	
	Settling Time	40ms max.	20ms max.
	Total Output System Transfer Type	60ms+1 scan	40ms+1 scan
	Maximum Error at 25°C	±0.3% of full scale	
	Temperature Coefficient	±0.02%/°C of full scale	
	Reproducibility after Stabilization Time	±0.4% of full scale	
Output error	Non-linearity	±0.01% of full scale	
	Output Ripple	30mV max.	
	Overshoot	0%	
	Maximum Error	±1.0% of full scale	
	Effect of Improper Output Terminal Connection	No damage	
Data	Digital Resolution	4096 (12 bits)	
	LSB Output Value	2.44mV (0 to 10V)	3.91μA (4 to 20mA)
	Data Format in Application	0 to 4095 (0 to 10V)	0 to 4095 (4 to 20mA)
	Monotonicity	Yes	
	Open Current Loop	—	Cannot be detected
Noise Resistance	Maximum Temporary Deviation during Electrical Noise Tests	±4.0 of full scale	
	Recommended Cable	Shielded twisted pair	
	Crosstalk	1 LSB max.	
Isolation		None	
Calibration to Maintain Rated Accuracy		Impossible	
Selection of Output Signal Type		Voltage output only	Current output only

Applicable Wire

Cartridge Part No.	FC6A-PJ2A	FC6A-PJ2CP	FC6A-PK2AV	FC6A-PK2AW
Applicable Wire	0.3mm2 (AWG22) shielded twisted pair	0.3mm2 (AWG22) twisted pair	0.3mm2 (AWG22) shielded twisted pair	

Input Specifications

Part No.	FC6A-PJ2A		FC6A-PJ2CP	
Input Type	Voltage Input	Current Input	Resistance Thermometer	Thermocouple
Input Range	0 to 10V DC	4 to 20mA DC 0 to 20mA DC	Pt100: -200 to +850°C Pt1000: -200 to +600°C Ni100: -60 to +180°C Ni1000: -60 to +180°C 3-wire RTD	K: -200 to 1300°C J: -200 to 1000°C R: 0 to 1760°C S: 0 to 1760°C B: 0 to 1820°C E: -200 to 800°C T: -200 to 400°C N: -200 to 1300°C C: 0 to 2315°C
Input Impedance	1MΩ min.	250Ω max.	1MΩ min.	
Allowable Conductor Resistance		—	10Ω max.	—
Input Detection Current		—	Typ: 0.2mA, 1.0mA max.	—
AD Conversion	Sample Duration Time	10ms		250ms
	Sample Interval	20ms		500ms
	Total Input System Transfer Time	20ms + 1 scan		500ms + 1 scan
	Type of Input	Single-ended input		
Operating Mode	Self-scan			
Conversion Method	SAR			
Input Error	Maximum Error at 25°C	±0.1% of full scale	±0.1% of full scale	±0.1% of full scale Cold junction compensation accuracy ±4.0°C or less Exceptions R, S thermocouple error: ±6.0°C (0 to 200 °C range only) B thermocouple error: Not guaranteed (0 to 300 °C range only) K, J, E, T, N thermocouple error: ±0.4% of full scale (0°C or lower range only)
	Temperature Coefficient	±0.02%/°C of full scale		
	Reproducibility After Stabilization Time	±0.5% of full scale		
	Non-linearity	±0.01% of full scale		
	Maximum Error	±1.0% of full scale		
Data	Digital Resolution	4096 (12 bits)	Pt100: 10,500 (14 bits) Pt1000: 8000 (13 bits) Ni100: 2400 (12 bits) Ni1000: 2400 (12 bits)	K: 15,000 (14 bits) J: 12,000 (14 bits) R: 17,600 (15 bits) S: 17,600 (15 bits) B: 18,200 (15 bits) E: 10,000 (14 bits) T: 6,000 (13 bits) N: 15,000 (14 bits) C: 23,150 (15 bits)
	LSB Input Value	2.44mV (0 to 10V DC)	4.88μA (DC0 to 20mA) 3.91μA (DC4 to 20mA)	0.1°C 0.18°F
	Data Format in Application	Can be arbitrarily set for each channel in the range of -32,768 to 32,773		
	Monotonicity	Yes		
Noise Resistance	Maximum Temporary Deviation during Electrical Noise Tests	±4.0% of full scale		
	Recommended Cable	Shielded twisted pair	Twisted pair	
	Crosstalk	1LSB max.		
Isolation	None			
Effect When Input is Incorrectly Wired	No damage			
Maximum Allowable Constant Load (non-destructive)	13V DC	40mA	13V DC	
Input Type Modification	Software programming			
Calibration to Maintain Rated Accuracy	Impossible			

Mounting Hole Layout

FT1A-*12RA-*

FT1A-*14*A-*

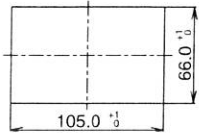

Note: Waterproof characteristic may not be obtained depending on the panel material and size.

LCD Active Area

LCD Type	X	Y
TFT	88.92	37.05
STN	87.59	35.49

All dimensions in mm.

Dimensions

Relay Output Model (FT1A-12RA-*)

When using mounting bracket (HG9Z-4K2PN04)

All dimensions in mm.

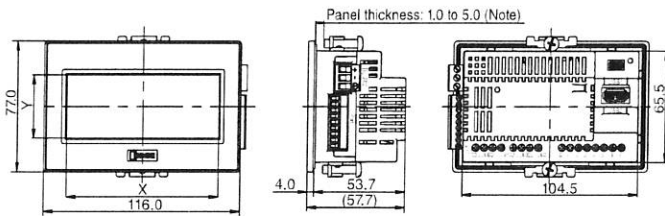

Transistor Output Model (FT1A-14KA-* / FT1A-14SA-*)

When using mounting bracket (HG9Z-4K2PN04)

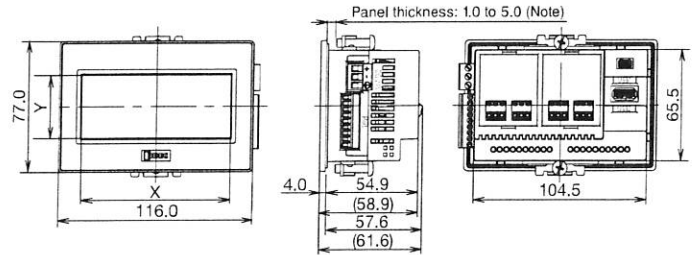

When using rear mount adapter (FT9Z-1A01)

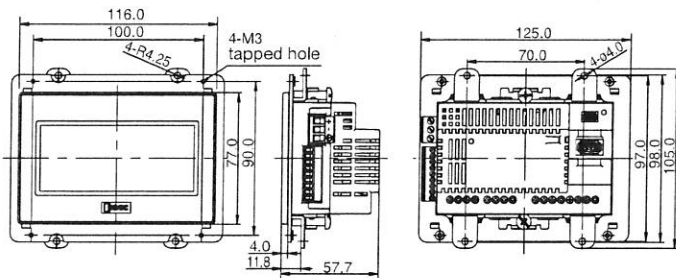

When using rear mount adapter (FT9Z-1A01)

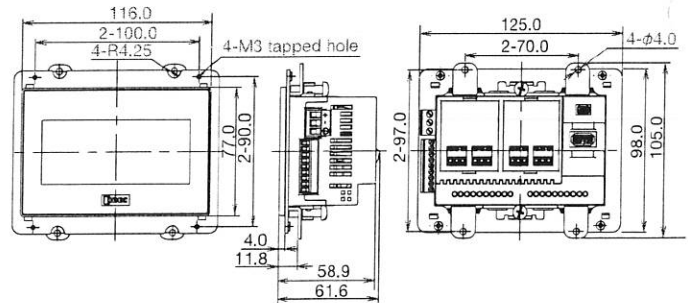

Terminal Arrangement and I/O Wiring Diagram Examples

Touch (Display Model)

FT1A-*12RA-*

For terminal arrangement and I/O wiring diagram, see User's Manual.

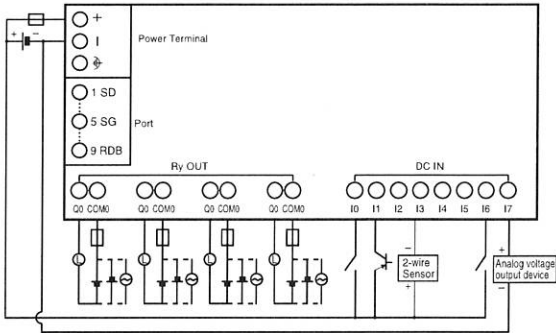

FT1A-*14KA-*

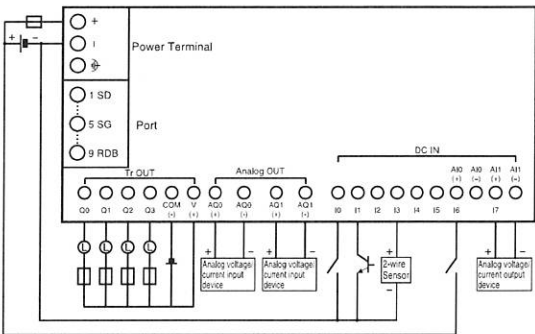

FT1A-*14SA-*

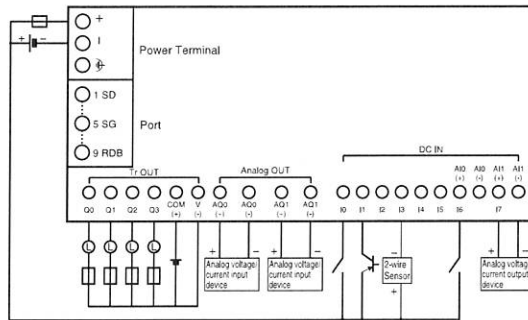

Recommended Ferrules for Touch/Pro/Lite Terminals

For 1-wire connection

For 2-wire connection

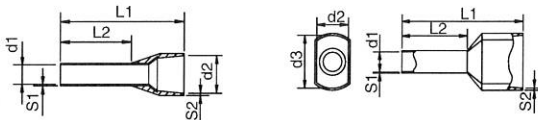

	Cross Section (mm ²)	AWG	Phoenix Contact Part No.	Touch				Pro/Lite				L1	L2	d1	S1	d2	d3	S2
				Power Supply	Serial Interface	I/O Relay Output Model	I/O Transistor Output Model	Power Supply	I/O									
1-wire connection	0.25	24	AI0.25-8YE					×		12.5	8.0	0.8	0.15	1.8			0.25	
	0.34	22	AI0.34-8TQ	×	×	×	×			12.5	8.0	0.8	0.15	2.0			0.25	
	0.5	20	AI0.5-8WH	×	×	×	×			14.0	8.0	1.1	0.15	2.5			0.25	
	0.75		AI0.75-8GY	×		×				14.0	8.0	1.3	0.15	2.8			0.25	
	1.0	18	AI1-8RD	×				×		14.0	8.0	1.5	0.15	3.0			0.3	
			AI1-10RD			×				16.0	10.0	1.5	0.15	3.0			0.3	
		1.5	16	AI1.5-8BK	×				×	14.0	8.0	1.8	0.15	3.4			0.3	
2-wire connection	0.5	20	AI-TWIN2x0.5-8WH	×	×		×			15.0	8.0	1.5	0.15	2.5	4.6		0.25	
	0.75	18	AI-TWIN2x0.75-8GY	×				×		15.0	8.0	1.8	0.15	2.8	5.2		0.25	
			AI-TWIN2x0.75-10GY			×				17.0	10.0	1.8	0.15	2.8	5.2		0.25	
Screwdriver			SZS 0.6x3.5	×		×		×										
			SZS 0.4x2.5		×		×											

Note: Crimping pliers - Phoenix Contact part number CRIMPFOX ZA3 (12101882)



IDEC Corporation • 1175 Elko Drive • Sunnyvale, CA 94089 • 800-262-IDEC (4332) • Fax: 408-745-5258 • www.IDEC.com/usa

©2014 IDEC Corporation. All Rights Reserved.



DoC No.	D1B136 D2B154
---------	------------------

DECLARATION OF CONFORMITY

We, IDEC CORPORATION
6-64, Nishimiyahara 2-chome
Yodogawa-ku, Osaka 532-0004, Japan

declare under our sole responsibility that the product:

Description: FT1A Controller
Series Name: SmartAXIS Touch
Model No.: Details are as per attached sheet

to which this declaration relates is in conformity with the EC Directive on the following standard(s) or other normative document(s). In case of alteration of the product, not agreed upon by us, this declaration will lose its validity.

Applicable EC Directive: EC Directive of Electromagnetic Compatibility (2004/108/EC)
Low Voltage Directive (2006/95/EC)

Applicable Standard(s): EN 61131-2

11 March, 2013 at Osaka, Japan

26 September, 2014 (Revised)

Atsushi Matsumoto
General Manager
Quality Assurance Center



DoC No.	D1B136 D2B154
---------	------------------

26 September, 2014

Page 1 of 2

FT1A Touch (Display Models):

- FT1A-M12RA-W Monochrome LCD, DC Power Supply, 8-DC Input, 4-Relay Output, Light Gray Bezel.
- FT1A-M12RA-B Monochrome LCD, DC Power Supply, 8-DC Input, 4-Relay Output, Dark Gray Bezel.
- FT1A-M12RA-S Monochrome LCD, DC Power Supply, 8-DC Input, 4-Relay Output, Silver Bezel.
- FT1A-M14SA-W Monochrome LCD, DC Power Supply, 6-DC Input, 2-DC Input or 2-Analog Input, 4-Transistor(source) Output, 2-Analog output, Light Gray Bezel.
- FT1A-M14SA-B Monochrome LCD, DC Power Supply, 6-DC Input, 2-DC Input or 2-Analog Input, 4-Transistor(source) Output, 2-Analog output Dark Gray Bezel.
- FT1A-M14SA-S Monochrome LCD, DC Power Supply, 6-DC Input, 2-DC Input or 2-Analog Input, 4-Transistor(source) Output, 2-Analog output Silver Bezel.
- FT1A-M14KA-W Monochrome LCD, DC Power Supply, 6-DC Input, 2-DC Input or 2-Analog Input, 4-Transistor(sink) Output, 2-Analog output Light Gray Bezel.
- FT1A-M14KA-B Monochrome LCD, DC Power Supply, 6-DC Input, 2-DC Input or 2-Analog Input, 4-Transistor(sink) Output, 2-Analog output Dark Gray Bezel.
- FT1A-M14KA-S Monochrome LCD, DC Power Supply, 6-DC Input, 2-DC Input or 2-Analog Input, 4-Transistor(sink) Output, 2-Analog output Silver Bezel.



DoC No.	D1B136 D2B154
---------	------------------

26 September, 2014
Page 2 of 2

- FT1A-C12RA-W Color LCD, DC Power Supply, 8-DC Input, 4-Relay Output, Light Gray Bezel.
- FT1A-C12RA-B Color LCD, DC Power Supply, 8-DC Input, 4-Relay Output, Dark Gray Bezel.
- FT1A-C12RA-S Color LCD, DC Power Supply, 8-DC Input, 4-Relay Output, Silver Bezel.
- FT1A-C14SA-W Color LCD, DC Power Supply, 6-DC Input, 2-DC Input or 2-Analog Input, 4-Transistor(source) Output, 2-Analog output Light Gray Bezel.
- FT1A-C14SA-B Color LCD, DC Power Supply, 6-DC Input, 2-DC Input or 2-Analog Input, 4-Transistor(source) Output, 2-Analog output Dark Gray Bezel.
- FT1A-C14SA-S Color LCD, DC Power Supply, 6-DC Input, 2-DC Input or 2-Analog Input, 4-Transistor(source) Output, 2-Analog output Silver Bezel.
- FT1A-C14KA-W Color LCD, DC Power Supply, 6-DC Input, 2-DC Input or 2-Analog Input, 4-Transistor(sink) Output, 2-Analog output Light Gray Bezel.
- FT1A-C14KA-B Color LCD, DC Power Supply, 6-DC Input, 2-DC Input or 2-Analog Input, 4-Transistor(sink) Output, 2-Analog output Dark Gray Bezel.
- FT1A-C14KA-S Color LCD, DC Power Supply, 6-DC Input, 2-DC Input or 2-Analog Input, 4-Transistor(sink) Output, 2-Analog output Silver Bezel.

Option Modules for FT1A-M14SA-□, FT1A-M14KA-□, FT1A-C14SA-□ and FT1A-C14KA-□

- FC6A-PJ2A 2-Analog Input
- FC6A-PJ2CP 2-Analog Input
- FC6A-PK2AV 2-Analog Output
- FC6A-PK2AW 2-Analog Output

CERTIFICATE OF COMPLIANCE

Certificate Number 20140725-E102542
Report Reference E102542-20121205
Issue Date 2014-JULY-25

Issued to: IDEC CORP
6-64 NISHIMIYAHARA 2-CHOME
YODOGAWA-KU
OSAKA 532-0004 JAPAN

This is to certify that PROGRAMMABLE CONTROLLERS
representative samples of See Addendum.

Have been investigated by UL in accordance with the
Standard(s) indicated on this Certificate.

Standard(s) for Safety: Standard for Industrial Control Equipment, UL 508 and CSA
C22.2 No. 142-M1987.

Additional Information: See the UL Online Certifications Directory at
www.ul.com/database for additional information

Only those products bearing the UL Listing Mark for the US and Canada should be considered as
being covered by UL's Listing and Follow-Up Service meeting the appropriate requirements for US
and Canada.

The UL Listing Mark for the US and Canada generally includes: the UL in a circle symbol with "C" and
"US" identifiers:  the word "LISTED"; a control number (may be alphanumeric) assigned by UL;
and the product category name (product identifier) as indicated in the appropriate UL Directory.

Look for the UL Listing Mark on the product.



William R. Carney, Director, North American Certification Programs
UL LLC

Any information and documentation involving UL Mark services are provided on behalf of UL LLC (UL) or any authorized licensee of UL. For questions, please
contact a local UL Customer Service Representative at www.ul.com/contactus



CERTIFICATE OF COMPLIANCE

Certificate Number 20140725-E102542
Report Reference E102542-20121205
Issue Date 2014-JULY-25

This is to certify that representative samples of the product as specified on this certificate were tested according to the current UL requirements.

CPU modules with Touch Panel,
FT1A-M12RA, -M14SA, -M14KA, -C12RA, -C14SA and -C14KA. Consists of the following modules:

CPU Modules with Touch Panel :
STN Monochrome LCD Type, Models FT1A-M12RA-W, -M12RA-B, -M12RA-S, -M14SA-W,
-M14SA-B, -M14SA-S, -M14KA-W, -M14KA-B, -M14KA-S.
TFT Color LCD Type, FT1A-C12RA-W, -C12RA-B, -C12RA-S, -C14SA-W, -C14SA-B,
-C14SA-S, -C14KA-W, -C14KA-B, -C14KA-S.

Option modules for Models FT1A-M14SA-*, FT1A-M14KA-*, FT1A-C14SA-* and FT1A-C14KA-* :
FC6A-PJ2A: 2-Analog Input
FC6A-PJ2CP: 2-Analog Input
FC6A-PK2AV: 2-Analog Output
FC6A-PK2AW: 2-Analog Output

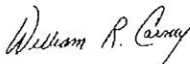

William R. Carney, Director, North American Certification Programs
UL LLC

Any information and documentation involving UL Mark services are provided on behalf of UL LLC (UL) or any authorized licensee of UL. For questions, please contact a local UL Customer Service Representative at www.ul.com/contactus



CERTIFICATE OF COMPLIANCE

Certificate Number 20141215-E211795
Report Reference E211795-20140430
Issue Date 2014-DECEMBER-15

Issued to: IDEC CORP
6-64 NISHIMIYAHARA 2-CHOME YODOGAWA-KU
OSAKA 532-0004 JAPAN

This is to certify that
representative samples of PROGRAMMABLE CONTROLLERS FOR USE IN
HAZARDOUS LOCATIONS
See addendum page

Have been investigated by UL in accordance with the
Standard(s) indicated on this Certificate.

Standard(s) for Safety: ANSI/ISA 12.12.01, 2013 Nonincendive Electrical
Equipment
CAN/CSA C22.2 No. 213-M1987 Non-incendive Electrical
Equipment

Additional Information: See the UL Online Certifications Directory at
www.ul.com/database for additional information

Only those products bearing the UL Certification Mark should be considered as being covered by UL's
Certification and Follow-Up Service.

Look for the UL Certification Mark on the product.

B. Mahlenz

Bruce Mahrenholz, Assistant Chief Engineer, Global Inspection and Field Services

UL LLC

Any information and documentation involving UL Mark services are provided on behalf of UL LLC (UL) or any authorized licensee of UL. For questions, please
contact a local UL Customer Service Representative at www.ul.com/contactus



CERTIFICATE OF COMPLIANCE

Certificate Number 20141215-E211795
Report Reference E211795-20140430
Issue Date 2014-DECEMBER-15

This is to certify that representative samples of the product as specified on this certificate were tested according to the current UL requirements.

Programmable Controller, CPU modules with Touch Panel,
FT1A series for use in Class I, Division 2, Groups A, B, C, D Hazardous Locations. Consists of the following modules:

CPU Modules with Touch Panel :

STN Monochrome LCD Type, Models FT1A-M12RA-W, -M12RA-B, -M12RA-S, -M14SA-W,
-M14SA-B, -M14SA-S, -M14KA-W, -M14KA-B, -M14KA-S.

TFT Color LCD Type, FT1A-C12RA-W, -C12RA-B, -C12RA-S, -C14SA-W, -C14SA-B, -C14SA-S, -C14KA-W, -
C14KA-B, -C14KA-S.

Option modules for Models FT1A-M14SA-*, FT1A-M14KA-*, FT1A-C14SA-* and FT1AC14KA-*:

FC6A-PJ2A: 2-Analog Input

FC6A-PJ2CP: 2-Analog Input

FC6A-PK2AV: 2-Analog Output

FC6A-PK2AW: 2-Analog Output



Bruce Mahrenholz, Assistant Chief Engineer, Global Inspection and Field Services

UL LLC

Any information and documentation involving UL Mark services are provided on behalf of UL LLC (UL) or any authorized licensee of UL. For questions, please contact a local UL Customer Service Representative at www.ul.com/contactus

