

IMPORTANT: OPW products should be used in compliance with applicable federal, state, provincial, and local laws and regulations. Product selection should be based on physical specifications and limitations and compatibility with the environment and materials to be handled. OPW MAKES NO WARRANTY OF FITNESS FOR A PARTICULAR USE. All illustrations and specifications in this literature are based on the latest product information available at the time of publication. OPW reserves the right to make changes at any time in prices, materials, specifications and models and to discontinue models without notice or obligation.



OPW 1000 Series Self-Service Nozzles (NGV1 Type 1) (CT1000)



OPW 1000 Series self-service nozzles are designed for high flow public and private CNG fueling systems. Applications include quick-fill, self-service fueling of automobiles, light trucks, shuttle buses and vans. All OPW NGV fueling nozzles are designed and built to exacting engineering specifications for fueling safety and efficiency

Table of Contents:

1. Features
2. Dimensions
3. Ordering Specifications

Features:

- User-Friendly Single-Action Operation - Engage nozzle and receptacle with a 180° rotation of the handle. This secures nozzle jaws onto receptacle, activating a system of three internal valves that regulate fueling. The nozzle will not dispense gas until securely engaged onto an appropriate receptacle. When fueling is complete, rotate the handle to the disconnect position to automatically stop the flow of gas into the vehicle, vent the trapped gas, and release the nozzle from the receptacle. The 1000 Series nozzles connect directly to the hose, with no need for a three-way valve. Designed for public or private self-service applications, no attendant is needed.
- High Flow/Fast-Fill Capability - Provides quick fueling of medium storage vehicles. Internal seals are designed for fast-fill NGV fueling.
- Internal Filter - Captures gas-borne debris commonly found in CNG systems. Filter protects against impurities in the high velocity gas stream that can damage the nozzle and receptacle seals and the vehicle fuel system.
- Directed Vent (CT1000) - Captures the gas vented at disconnect and directs it out of the nozzle via a 1/4" stainless-steel vent tube which can be piped to a remote venting location or back to the upstream side of the compressor. Capturing vent gas is environmentally desirable by agencies such as EPA, and provides an added measure of safety by minimizing the amount of gas present at the filling site. It also reduces vent noise and eliminates escaped gas smell.
- Jaw-Lock Technology - Designed specifically for the frequent coupling and uncoupling of the high pressure gas connections of NGV fueling. Forces at the contact point are distributed over the entire surface area of the receptacle.
- Ergonomic Design - One simple and convenient motion ensures connection and dispensing by all users. Insulated jacket protects operator's hand.
- Durable Construction - Heavy-duty brass and stainless-steel construction provides corrosion resistance in the harsh refueling environment.
- Meets NGV1 Fueling Standard - Can be used to fuel any vehicle with an NGV1 profile receptacle.
- Tamper Resistant - Specially designed cam system actuates the front and rear module. Tampering with the valve results in immediate dispensing shut-off.
- Individually Leak Tested and Inspected with Traceable Serial Number.
- Agency Listings - ASME Pressure Vessel Registered, Railroad Commission of Texas, ANSI/AGA/CGA NGV1 Type 1 (CT1000). Class A Certified, German Pressure Vessel Ordinance (Druckbeh V) Approved (P30 models only). Bauart number 02CDN1

Materials:

Body: Brass

Internal Components: Stainless Steel

Seals: Specially blended polymers and elastomers specific to high pressure NGV

applications.

Dimensions

	CC1000		CT1000S		CT1000L/CT1000P36	
	in	mm	in	mm	in	mm
A	6.25	159.1	6.69	167.8	7.32	185.8
B	2.56	66.1	2.63	65.4	2.63	66.4
C	1.94	49.4	1.94	48.9	1.94	48.9
D	3	75.5	3.37	85.1	4	102.1
E	3.69	93	4.06	102.4	4.69	119.4
F	N/A	N/A	7.5	191	8.19	208
G	3.06	78.5	3.25	83.1	3.25	83.1
H	1.5	37.9	1.5	37.9	1.5	37.9
I	N/A	N/A	1.37	20.7	0.81	20.7
J	1.5	24.2	1.13	28.8	1.13	28.8
K	Straight Thread O-Ring Boss Port		SAE J1926-6 (9/16-18UNF-2B)			

Key

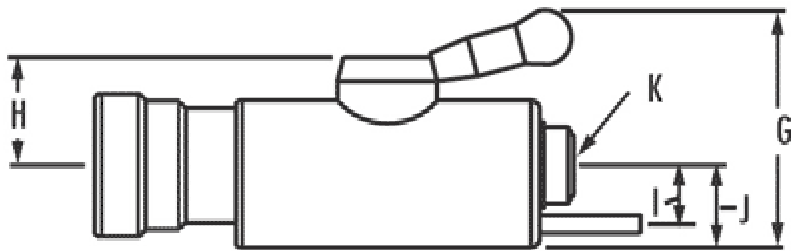
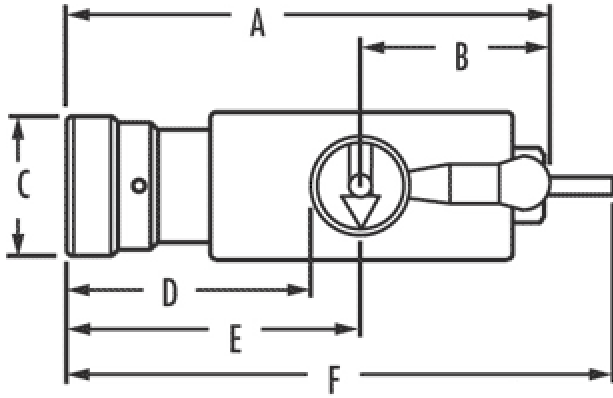

Specifications:

Min. Flow Rate: 1200 SCFM @ 3000 psid

Temperature Range: -40° C to 85° C
(-40° F to 185° F)

Weight: 1.52 kg. (3.35 lb.)

Cv: 0.48

Design Pressure: 4500 psi (310 Bar)

Certified



Ordering Information

Product No.	Inlet Thread Size	Maximum Allowable Service Pressure
CC1000	SAE - 6, 9/16 - 18 UNF	3000 psi (200 Bar)
CC1000S (Same as CC1000 with Stainless Steel Jaws)	3000 psi (200 Bar)	
CT1000S (directed vent)	SAE - 6, 9/16 - 18 UNF	3000 psi (200 Bar)
CT1000SS (Same as CT1000S with Stainless Steel Jaws)	3000 psi (200 Bar)	
CT1000L (Same as CT1000S and (directed vent) includes Guide Ring)	3000 psi (200 Bar)	
CT1000LS (Same as CT1000L with Stainless Steel Jaws)	3000 psi (200 Bar)	
CT1000-P36 (directed vent)	SAE - 6, 9/16 - 18 UNF	3600 psi (248 Bar)
CT1000-P36S (directed vent)	SAE - 6, 9/16 - 18 UNF	3600 psi (248 Bar)

A156

CT1000S S.S. Jaw
Replacement Kit

A158

CT1000L S.S. Jaw
Replacement Kit

A159

CT1000-P36. S.S. Jaw
Replacement Kit

NOTE: Available with Stainless Steel Jaws for more demanding applications. Add suffix S to product number. • Connects to any L-Series-NGV-1 CNG Receptacle

