

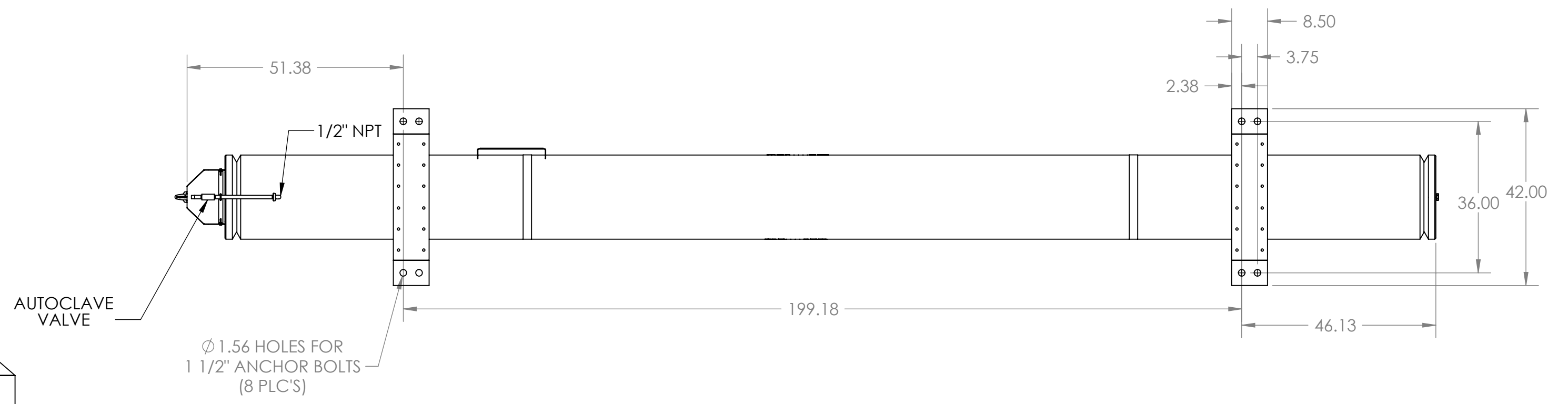

DETAIL A
SCALE 1 : 4



PROPRIETARY AND CONFIDENTIAL			DIMENSIONS ARE IN INCHES			WILCO MACHINE AND FAB, INC.
THE INFORMATION CONTAINED IN THIS DRAWING IS THE SOLE PROPERTY OF WILCO MACHINE & FAB, INC. ANY REPRODUCTION IN PART OR AS A WHOLE WITHOUT THE WRITTEN PERMISSION OF WILCO MACHINE & FAB, INC. IS PROHIBITED.			TOLERANCES UNLESS OTHERWISE SPECIFIED:			
COMMENTS:			FABRICATION	MACHINE	TITLE: ASSY-CNG-STORAGE TANKS-3 X 24'-CYLINDRICAL-STACKED-CUSTOMER	
Drawn	Date	Name	MATERIAL		SIZE	REV
Checked	04/12/10	P.A.S.	FINISH		C	A
Eng. Appr.	04/12/10	R.D.K.	DO NOT SCALE DRAWING		DWG. NO. 187240-L24-3-CUSTOMER	SHEET 1 OF 1
			SCALE: 1:24		WEIGHT: xxxxxx	