

PETK

Power and End Termination Kit

INSTALLATION PROCEDURES

- PETK-1D** for **BSX, RSX, VSX**
- PETK-2D** for **KSX, HTSX**
- PETK-3D** for **HPT, FP**

Order separately to be used in conjunction with
Thermon connection kits

**MADE IN
USA**



The Heat Tracing Specialists®

PETK

Receiving, Storing and Handling . . .

1. Inspect materials for damage incurred during shipping.
2. Report damages to the carrier for settlement.
3. Identify parts against the packing list to ensure the proper type and quantity has been received.
4. Store in a dry location.

PETK Power and End Termination Kits (per cable)

PETK-1D for BSX, RSX, VSX

PETK-2D for KSX, HTSX

PETK-3D for HPT, FP

Kit Contents . . .



Item	Quantity	Description
1	1	RTV Tube
2	1	Power Connection Boot
3	1	End Cap
4	1	Tape Strip (PETK-3D Only)
5	1	End Termination Caution Label
6	1	GRW-G Grommet (For PETK-3D Terminator kits only)

Installation Precautions . . .

- To minimize the potential for arcing and fire caused by product damage or improper installation use ground-fault protection. The National Electrical Code (NEC) and Canadian Electrical Code (CEC) require ground-fault protection of equipment for each branch circuit supplying electric heat tracing.
- Installation must comply with Thermon requirements and be installed in accordance with the NEC, CEC, or any other applicable national and local codes.
- Component approvals and performance ratings are based on the use of Thermon specified parts only.
- De-energize all power sources before opening enclosure.
- Keep ends of heating cable and kit components dry before and during installation.
- Individuals installing these products are responsible for complying with all applicable safety and health guidelines. Proper Personal Protective Equipment (PPE) should be utilized during installation. Contact Thermon if you have any additional questions.

PETK Certifications/Approvals¹ . . .



Note:

1. These sets have been evaluated as components of Thermon's Approved connection kits, such that the area use ratings depend on the rating of the connection kits.

Tools Required . . .

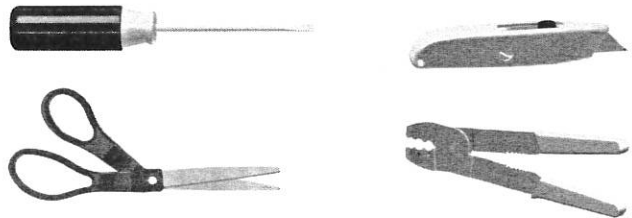

The Heat Tracing Specialists®

PETK

INSTALLATION PROCEDURES

IMPORTANT!

Heating cable must be properly installed within expediter assembly and mounted to pipe prior to terminating with PETK kit.

See Terminator and/or TracePlus Installation Instructions for expediter mounting details.

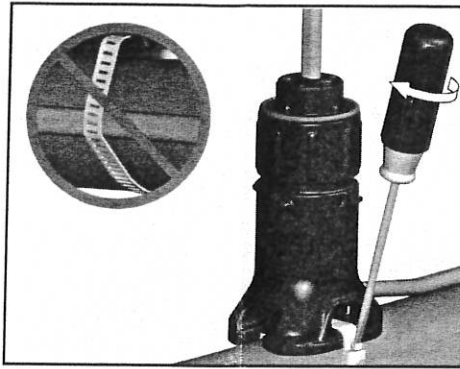

Terminator: Route cable through base entry and mount expediter to pipe using pipe band. Do not band over cable.

Note: For HPT and FP cable exchange grommet in Terminator with GRW-G provided in PETK-3D.

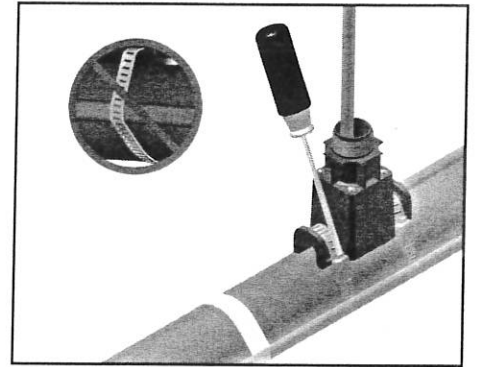

TracePlus: Route cable through base entry and mount expediter to pipe using pipe band. Do not band over cable.

Step 1: Remove Heating Cable Overjacket and Separate Metallic Braid to Form Pigtail

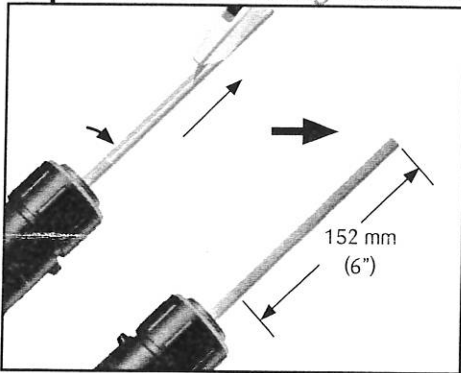

1a. Cut and remove heating cable overjacket.



Do not cut metallic braid.

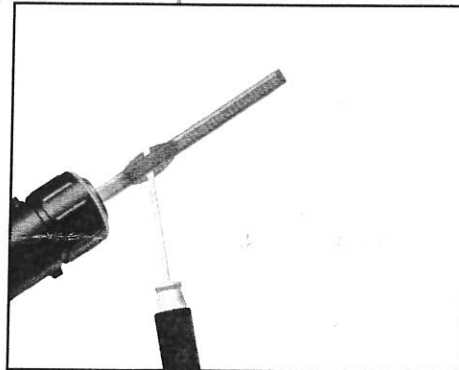

1b. Separate braid strands at edge of overjacket and pull cable through opening in braid.

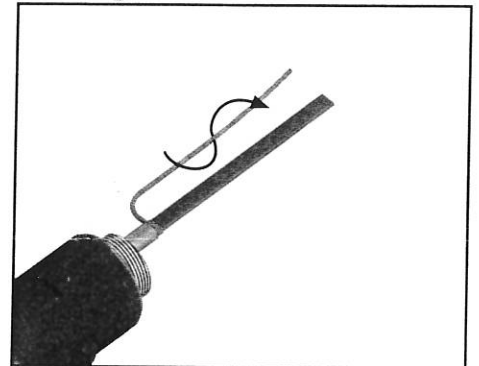

1c. Twist braid into a pigtail. Trim ends of braid.

Step 2: Matrix Removal for BSX, RSX, HTSX, KSX, and VSX Cables

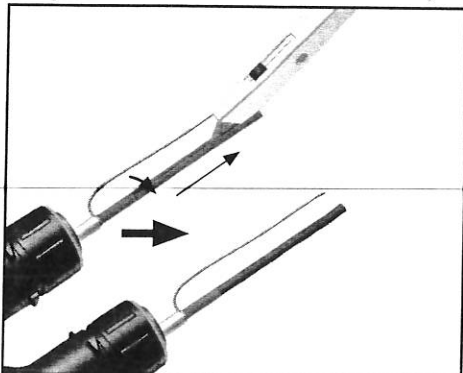

2a. Cut and remove primary insulation jacket (BSX and RSX cables only).

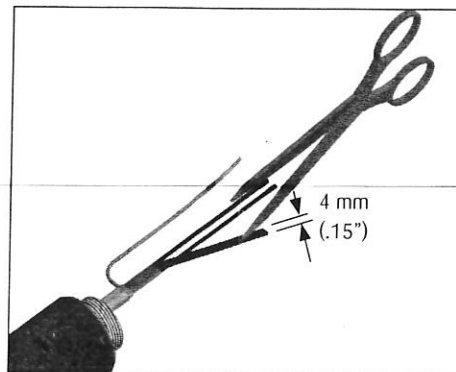

2b. Cut a 4 mm strip of conductive matrix between the conductors.



Do not cut bus wire strands.

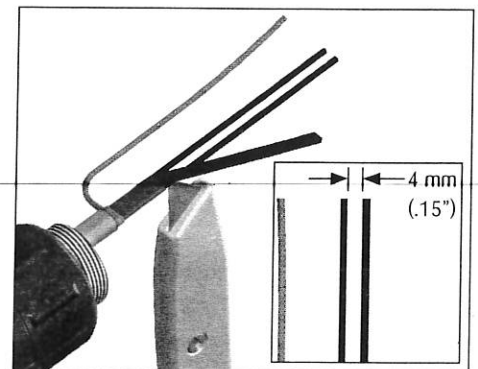

2c. Cut and remove the 4 mm matrix strip.

Step 2: Heating Element Removal for HPT and FP Cables

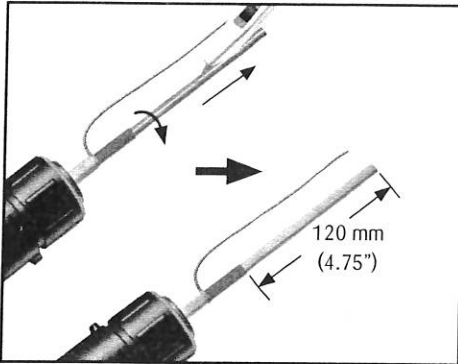

2a. Cut and remove primary insulation jacket.

NOTE: Bus connection must be no more than 50 mm (2") from pipe as addressed in connection kit instructions.

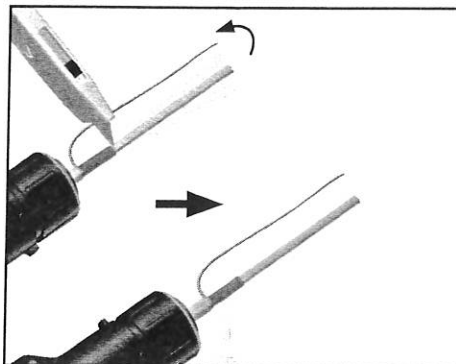

2b. Cut and remove fiberglass overlay and heating element. Push any remaining heating element wire under the primary insulation jacket.

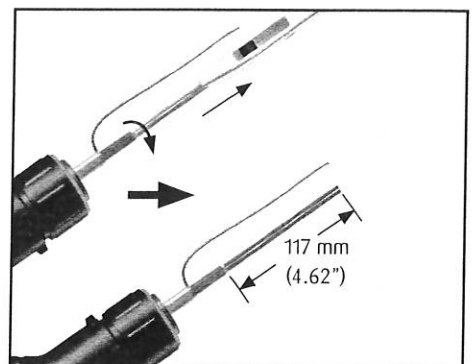

2c. Cut and remove pairing jacket.



Do not cut bus wire insulation.

Step 3: Install Power Boot on Heating Cables

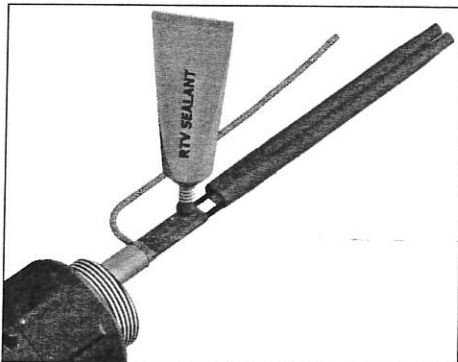

3a. Apply RTV sealant to cable to cover distance of at least 3mm and slide boot onto the end of the cable.

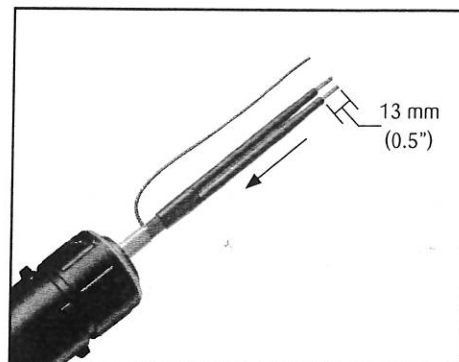

3b. Slide boot onto the end of the cable. Expose 13mm (0.5") of bus wire.



Step 4: End Termination for BSX, RSX, HTSX, KSX and VSX

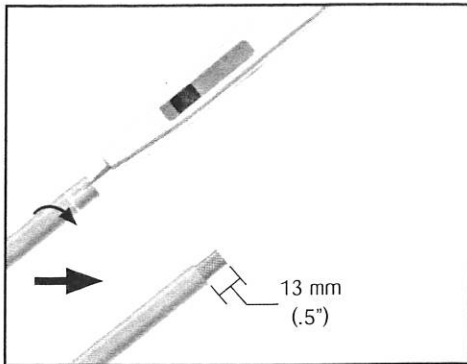

4a. Cut and remove heating cable overjacket.

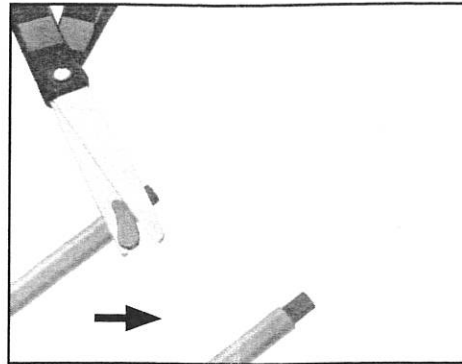

4b. Trim away exposed braid from cable.

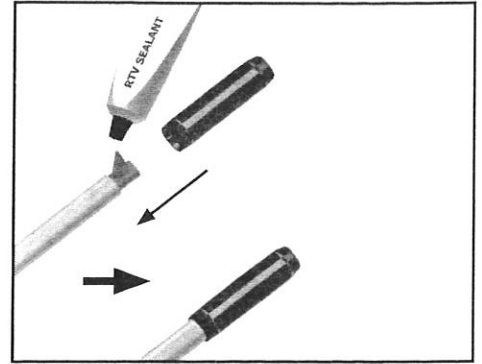

4c. Fill the end cap with RTV sealant and apply a circumferential bead to cable [minimum of 3 mm (0.12") wide]. Slide end cap onto end of cable.

Step 4: End Termination for HPT and FP

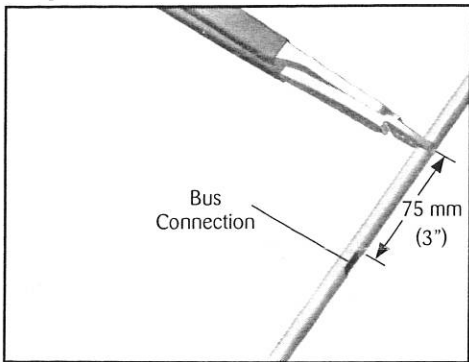

4a. Trim the cable 75mm (3") from the bus connection.

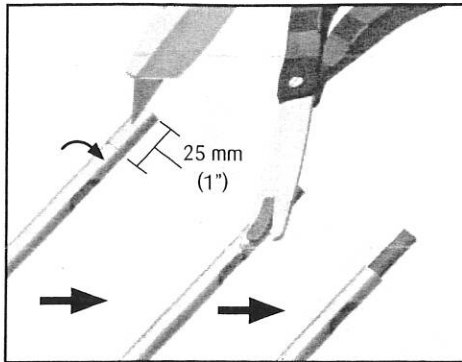

4b. Cut and remove overjacket and trim away exposed braid from cable.

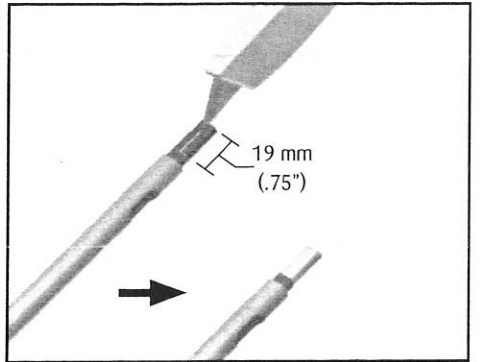

4c. Cut and remove primary insulation jacket.

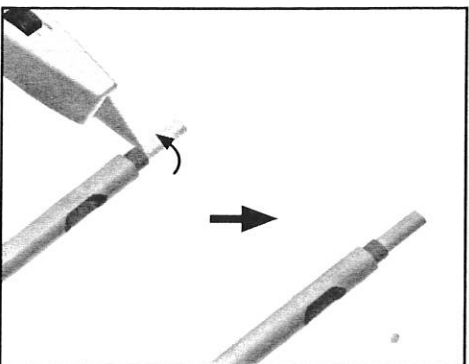

4d. Cut and remove fiberglass overlay and heating element. Push any remaining heating element wire under the primary insulation jacket.

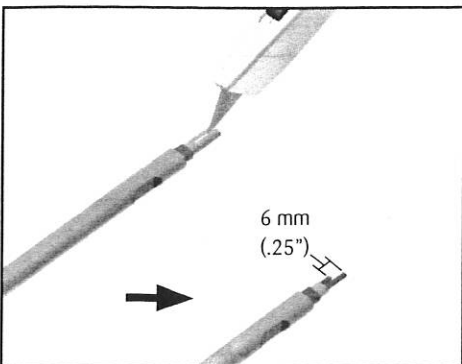

4e. Cut and remove pairing jacket. Stagger cut one of the bus wires.



Do not cut bus wire strands.

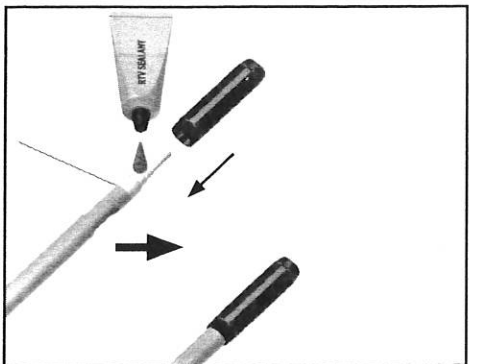

4f. Tape bus wires individually and then together. Continue taping to cover overjacket. Fill the end cap with RTV sealant and apply a circumferential bead to cable [minimum of 3 mm (0.12") wide]. Slide end cap onto end of cable.

Cable Take-off for BSX, RSX, HTSX, KSX and VSX

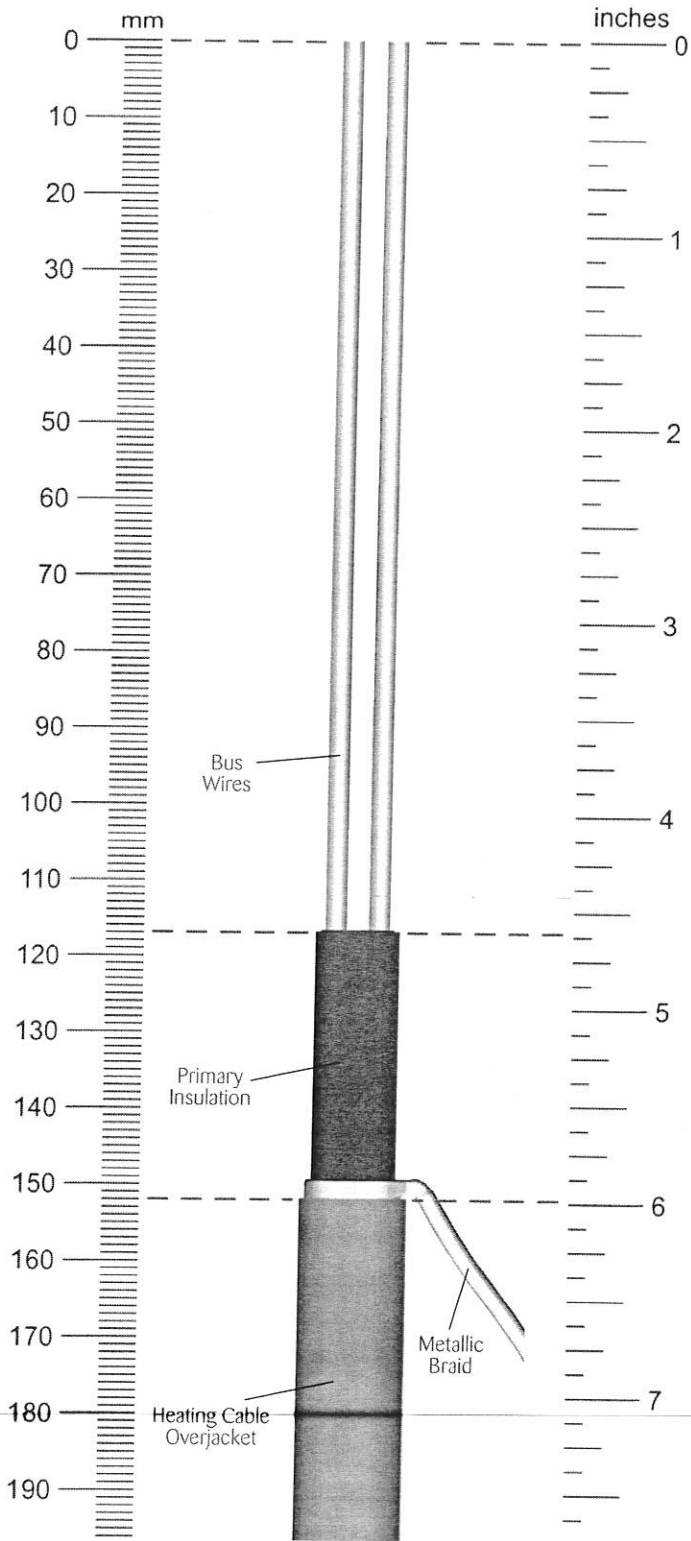

For Power Connector Boot Termination

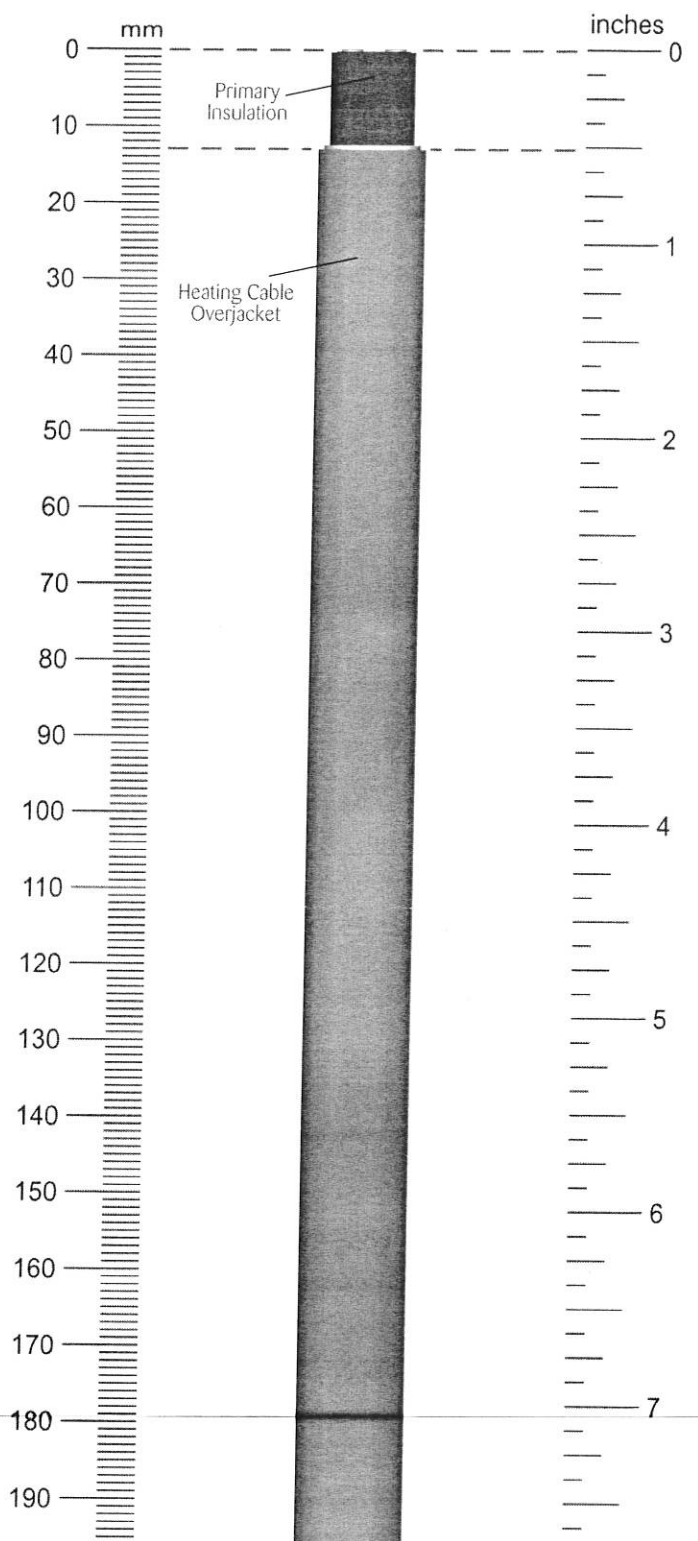

For End Cap Termination

Cable Take-off for HPT and FP Heating Cables

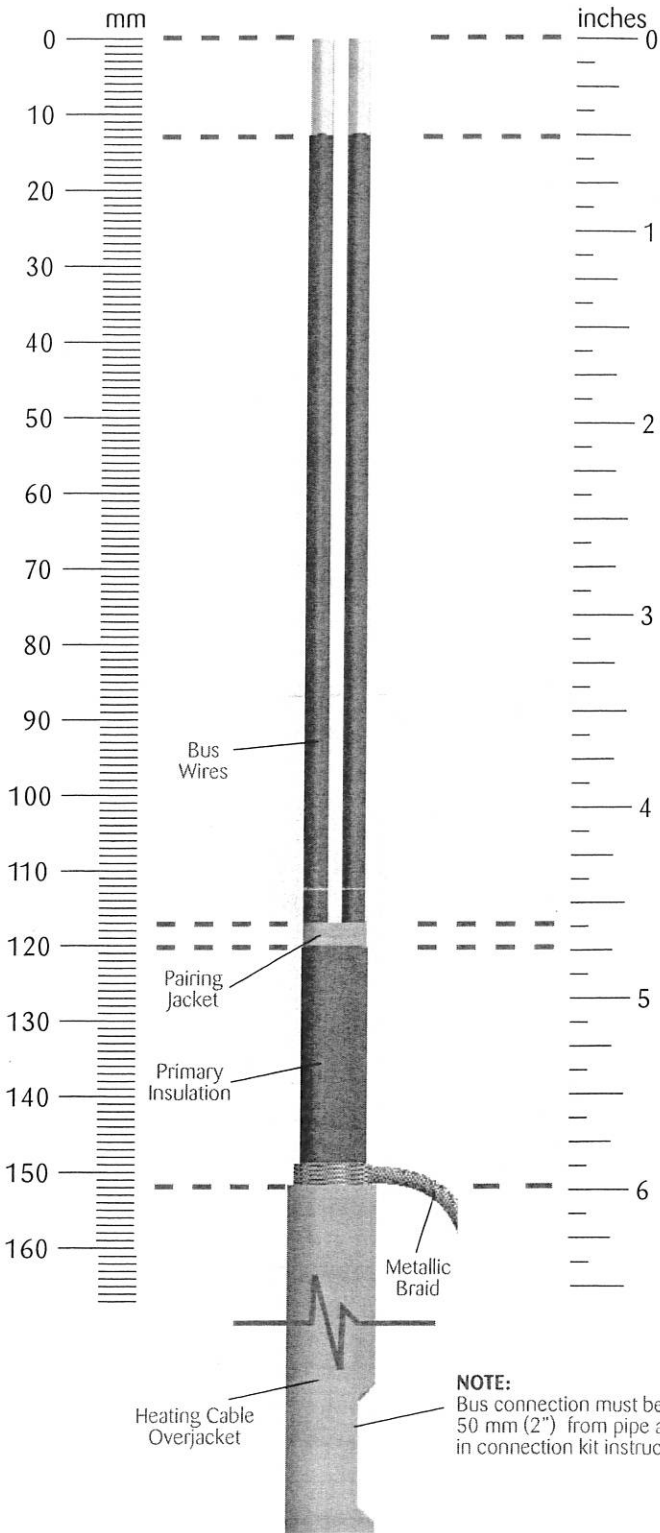

For Power Connection Boot Termination

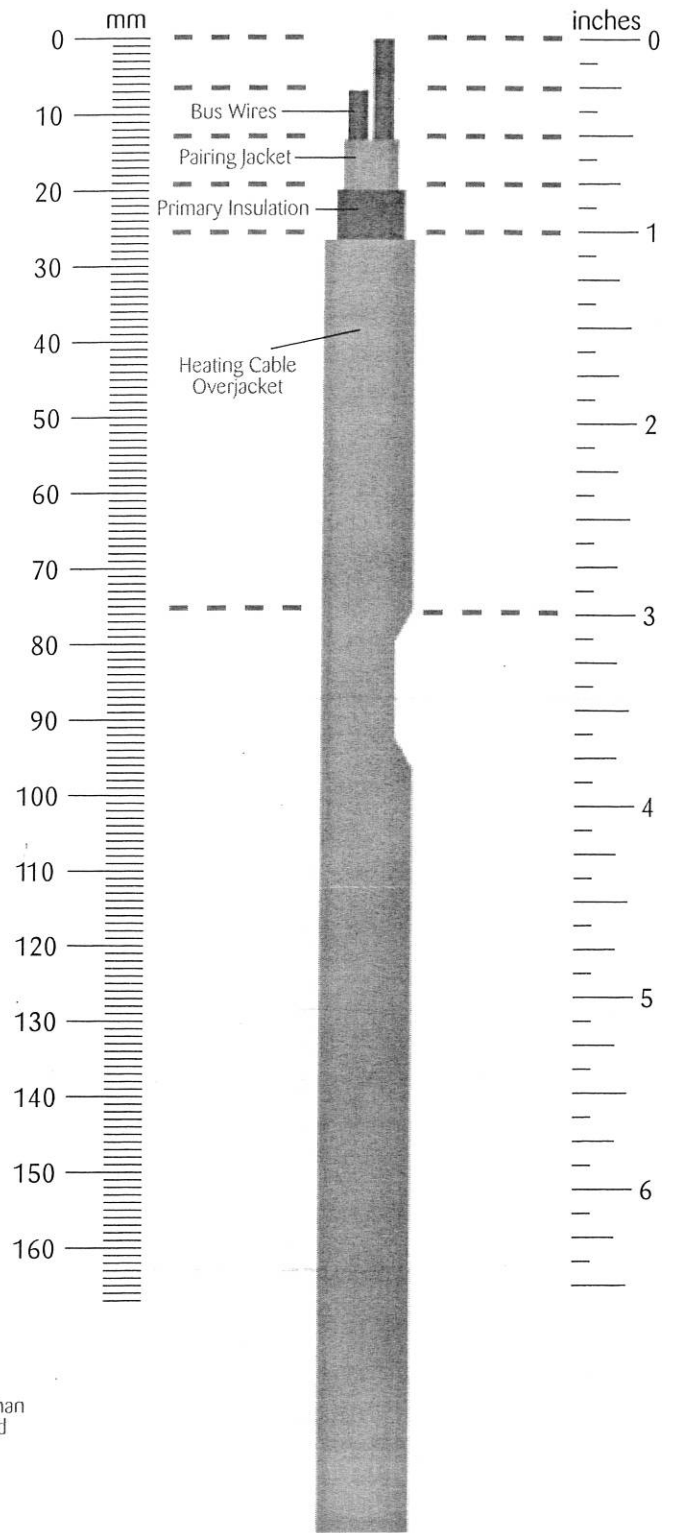

For End Cap Termination

NOTE:
 Bus connection must be no more than 50 mm (2") from pipe as addressed in connection kit instructions.



THERMON . . . The Heat Tracing Specialists*

100 Thermon Dr. • PO Box 609 • San Marcos, TX 78667-0609
 Phone: 512-396-5801 • Facsimile: 512-396-3627 • **1-800-820-HEAT**
 www.thermon.com

In Canada call **1-800-563-8461**

Specifications and information are subject to change without notice. Form 50132-0513

For the Thermon office nearest you
 visit us at . . .
 www.thermon.com

