

8500 SERIES

Up To 6,000 PSI



Also, ask for the 3B Interchange Guide with over 100,000 interchange elements available.



4642 West 92nd Street
Oak Lawn, IL 60453
Phone (708) 636-6240
Toll Free 866-3BFILTERS (323-4583)
Fax (708) 636-6251
sales@3bfilters.com

10 - GPM Size / 233 Element

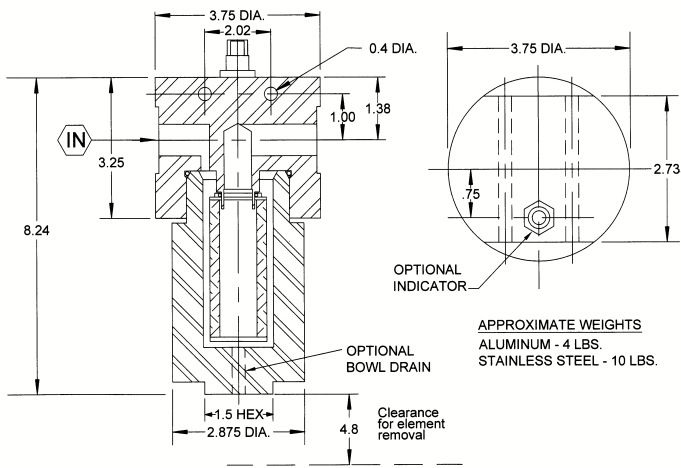

16 - GPM Size / 234 Element

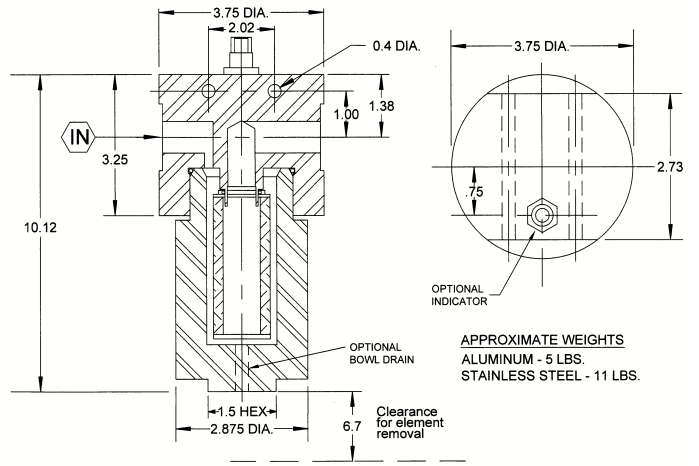

24 - GPM Size / 284 Element

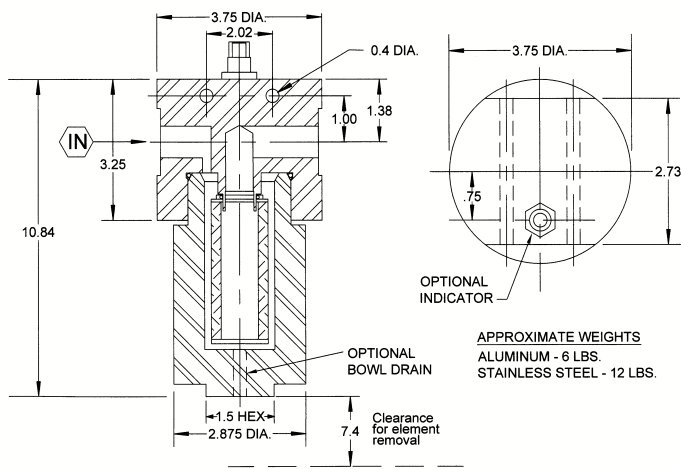

35 - GPM Size / 285 Element

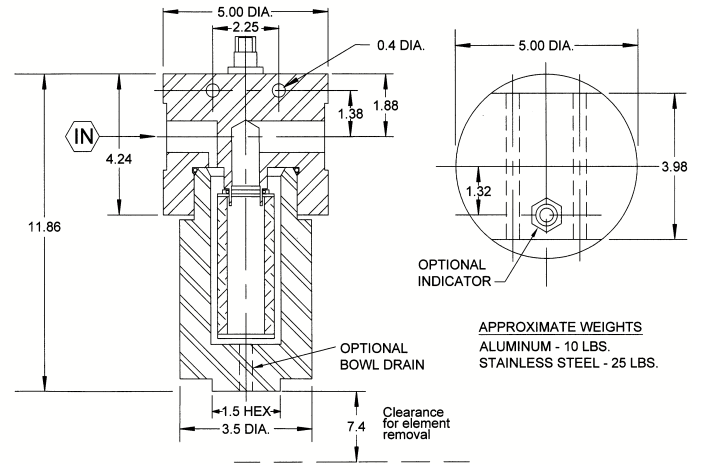

50 - GPM Size / 286 Element

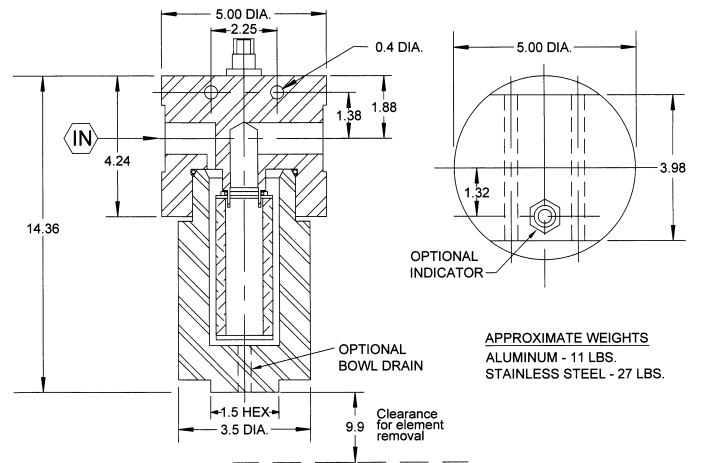

Pressure Specification

Housing	A	S	G
Material	Aluminum	303 SS	316 SS
Operating (psi)	5,000	6,000	6,000
Proof (psi)	7,500	9,000	9,000
Burst (psi)	20,000	24,000	24,000

HOW TO ORDER

EXAMPLE ASSEMBLY

A 8550-N10WE - ACCESSORIES									
T	T	T	T	T	T	T	T	T	T
A	B	C	D	E	F	G	H	I	

EXAMPLE REPLACEMENT ELEMENT

2	3	3	-	25	M	D	V
T	T	T		T	T	T	T
C				E	F	D	

(ELEMENT SIZE ON CHART)

A

HOUSING MATERIAL	
A	Aluminum
S	303 Stainless
G	316 S.S.

B

HOUSING PRESSURE	
85	Aluminum 5000 PSI
85	303, 316 Stainless 6000 PSI

C

PORT SIZE						
FLOW	GPM	10	16	24	35	50
	SCFM	300	600	1200	2500	4000
PORT SIZE	IDENTIFICATION NUMBER					
ELEMENT SIZE	233	234	284	285	286	
¼" NPT	25	27	29			
½" NPT	50	52	54			
¾" NPT	75	77	79			
1" NPT	86	88	90	92	94	
1 ¼ NPT				96	98	
1 ½ NPT				97	99	
½" S.A.E.-8	15	17	19			
¾" S.A.E.-12	35	37	39			
1" S.A.E.-16	41	43	45	47	49	
1 ¼" S.A.E.-20				65	67	
1 ½" S.A.E.-24				85	87	

D

O-RING SPECIFICATIONS		
CODE	MATERIAL	TEMPERATURES
N**	Nitrile(Buna)	-40° to 250°F
V**	Viton®	-20° to 400°F
E	Ethylene Propylene	-60° to 300°F
K	Kalrez®	-40° to 550°F
S	Teflon Encapsulated Viton Core	-4° to 400°F

**for 90- durometer add 9 to code (example: V9)
©DuPont

E

MICRON RATING					
#	NOM.	ABS	W	C	M
3C	3	10		x	
10C	10	25		x	
1M	-	1			x
3M	-	3			x
6M	-	6			x
12M	-	12			x
25M	-	25			x
10W	2	10	x		
18W	5	18	x		
25W	10	25	x		
75W	40	75	x		
150W	100	150	x		
1PM	.05	.20			
2PM	.20	.70			
3PM	.30	2			
4PM	.80	5			

NOTE:
C = Cellulose
M = Microglass
W = S.S. wire mesh
PM = Sintered Metal

F

COLLAPSE RATING	
CODE	DESCRIPTION
A	Cellulose 150-PSI
B	Cellulose 300-PSI
C	Microglass 300-PSI
D	Microglass 3,250-PSI
E	304 Wire Mesh 4,5000-PSI
F	316 Sintered 2,000-PSI

G

ACCESSORIES	
V	Visual Indicator ***
E	Electrical Indicator ***
D1	1/8 NPT △ P Port
D2	1/4 NPT △ P Port
D4	1/4 SAE △ P Port
DC	DIN - Connector (Includes E)

H

B* - Bypass**
* Insert Pressure Setting Default is 50 PSID

** Bypass is not available with △ P Port

I

BOWL DRAIN	
B1	1/8 NPT
B2	1/4 NPT
B4	1/4 SAE

*** Contact Factory for Pressure Limitations



4642 West 92nd Street
Oak Lawn, IL 60453
Phone (708) 636-6240
Toll Free 866-3BFILTERS (323-4583)
Fax (708) 636-6251
sales@3bfilters.com

FLOW DATA (PRESSURE DROP vs. FLOW)

Housing Less Assembly

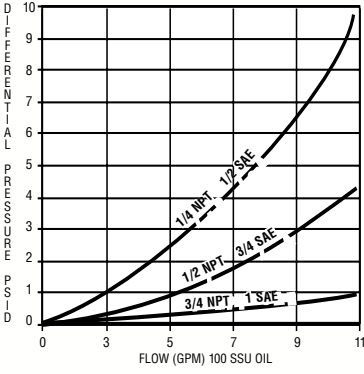

233 Cellulose Elements

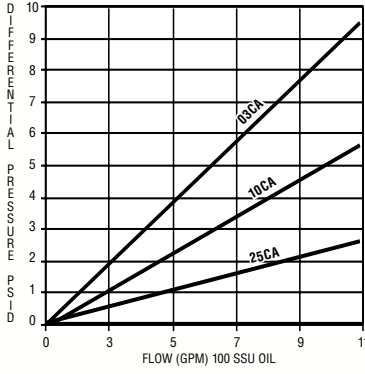

233 Micro-Glass Elements

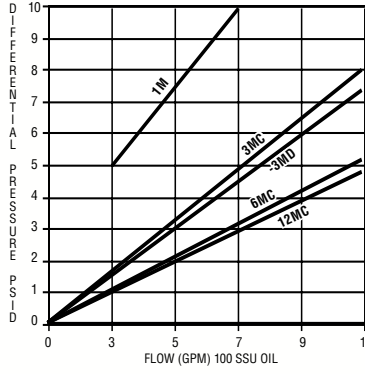

233 Stainless Elements

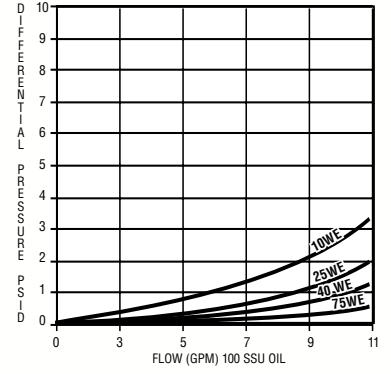

Housing Less Assembly

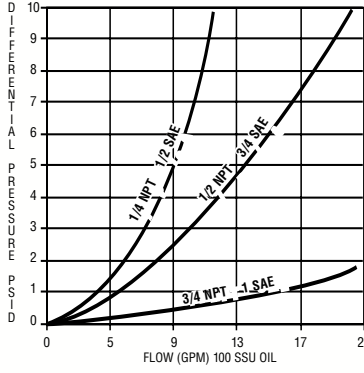

234 Cellulose Elements

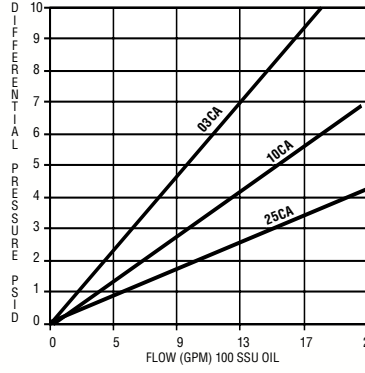

234 Micro-Glass Elements

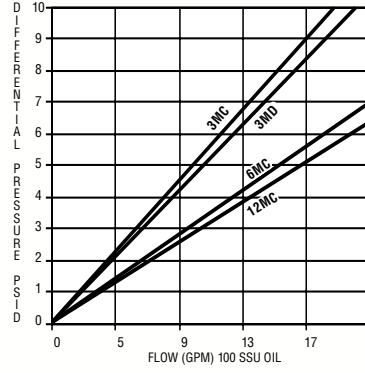

234 Stainless Elements

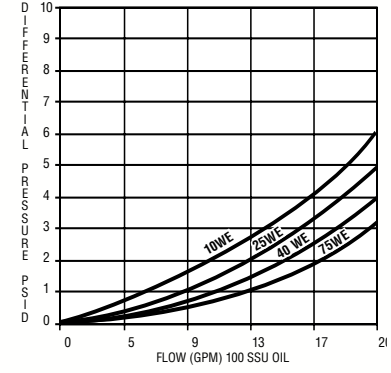

Housing Less Assembly

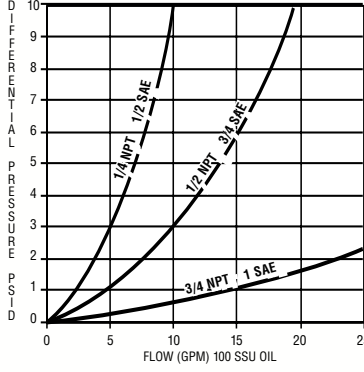

284 Cellulose Elements

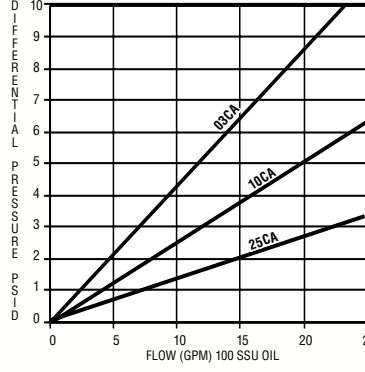

284 Micro-Glass Elements

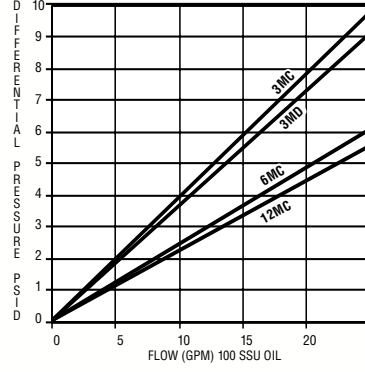

284 Stainless Elements

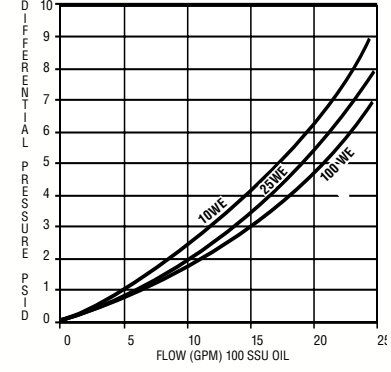

Housing Less Element

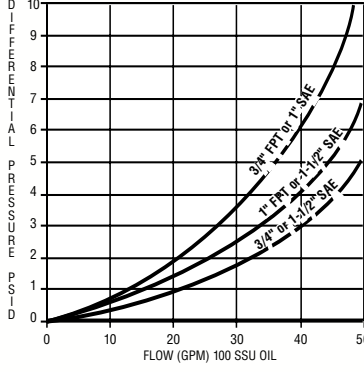

285 Reinforced Cellulose Elements

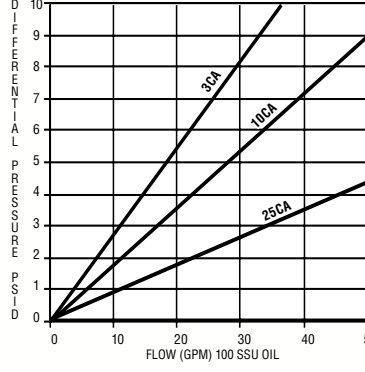

285 Series Glass Fiber Elements

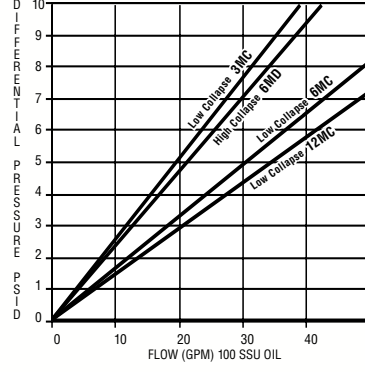

285 Series Stainless Elements

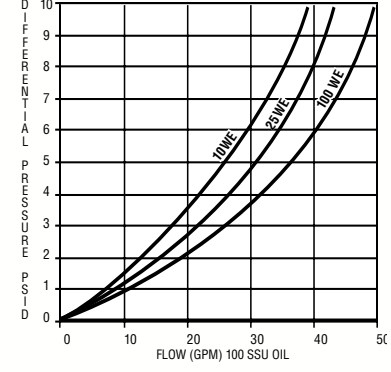

Housing Less Element

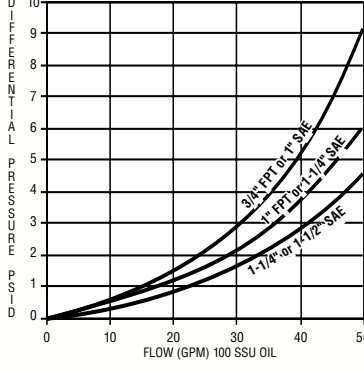

286 Reinforced Cellulose Elements

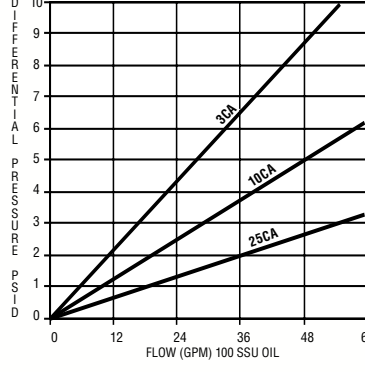

286 Series Glass Fiber Elements

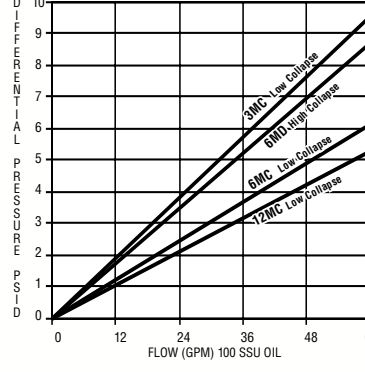

286 Series Stainless Elements

