

Shock and Vibration Switch



VS2 Series

- Designed to Detect Shock/Vibration in 3-Planes of Motion
- Fully Adjustable
- Includes Magnetic Latching Feature
- Manual or Electric Reset

Description

The VS2 Series switches are shock sensitive mechanisms for shutdown of engine or electric motor powered equipment. These switches use a magnetic latch to ensure reliable operation. Explosion-proof "EX" models for hazardous locations are available.

Applications

Ideal for use on engines, pumps, compressors, heat exchangers and pumping units, the VS2 Series can be used anywhere shutdown protection from damaging shock/vibration is desired. Switches are field adjustable to sensitivity required in each application.

Specifications

VS2 and VS2C

Case: Equal to NEMA 3R. Suitable for non-hazardous areas.

VS2: *Base mount*

VS2C: *C-clamp mount, includes 45 ft. (13.7 m) 2-conductor cable, and 5 cable clamps.*

Contacts: SPDT-double make leaf contacts, 5A @ 480 VAC.

VS2EX

Case: Base mount, explosion-proof aluminum alloy housing; meets NEMA 7/IP50 specifications; Class I, Division 1, Groups C & D; UL and CSA listed*.

Snap-switches: 2-SPDT snap-switches; 5A @ 480 VAC;* 2A resistive, 1A inductive, up to 30 VDC.

Normal Operating Temperature: -40 to 140°F (-40 to 60°C).

VS2EXR

Case: Same as VS2EX.

Snap-switch: 1-SPDT snap-switch and reset coil; 5A @ 480 VAC;* 2A resistive, 1A inductive, up to 30 VDC.

Remote Reset : 115 VAC or 24 VDC (specify).

VS2EXRB

Case: Explosion-proof aluminum alloy housing; rated Class I, Division 1, Group B hazardous areas.

Snap-switch: 1-SPDT snap-switch with reset coil (option available for 2-SPDT switches); 5A @ 480 VAC; 2A resistive, 1A inductive, up to 30 VDC.

Remote Reset: 115 VAC or 24 VDC (specify).

Basic Operation

Pushing the reset button moves the tripping latch into a magnetically held position. A shock/vibration will move the magnet beyond this holding position, thus freeing the spring loaded tripping latch to transfer the contacts and shutdown the machinery (see dimensional diagrams in the following pages for visual representation of parts).

Remote Reset Option (VS2EXR and VS2EXRB)

The remote reset option includes a built-in electric solenoid which allows reset of tripped unit from a remote location. Available for 115 VAC or 24 VDC.

Warranty

A limited warranty on materials and workmanship is given with this FWMurphy product. A copy of the warranty may be viewed or printed by going to www.fwmurphy.com/warranty.asp.

*CSA and UL listed with 480 VAC rating.



VS2 and VS2C

The VS2 and VS2C are designed for use in non-hazardous locations. They have leaf type SPDT, double make contacts that can be used for shutdown and/or alarm. They have a slotted sensitivity adjustment located on the side of the case (see drawing below).

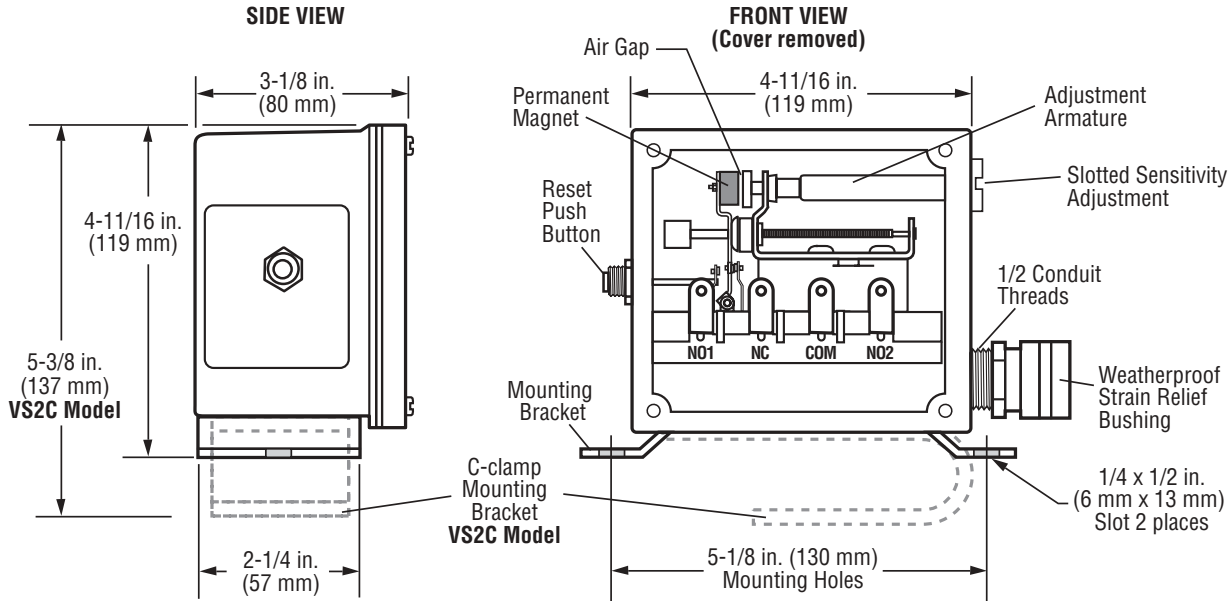
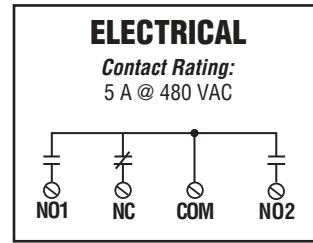

VS2EX

- NEMA 7/IP50 Specifications
- Snap-switch Contacts
- TATTLETALE® Reset Button

Model VS2EX is housed in an explosion-proof enclosure with threaded cover. This enclosure is CSA and UL listed for Class I, Division 1, Groups C & D hazardous locations. In place of the leaf type contacts, 2-SPDT snap-switches are used in this model. Sensitivity is externally adjustable and, when tripped, the VS2EX gives a TATTLETALE® indication on the reset button. It is constructed to meet NEMA 7 specifications.

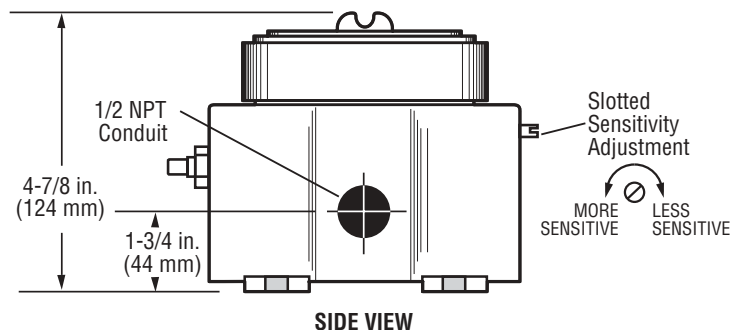
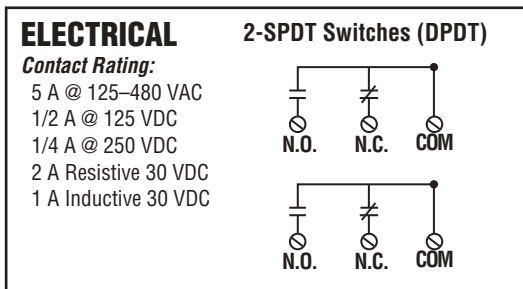
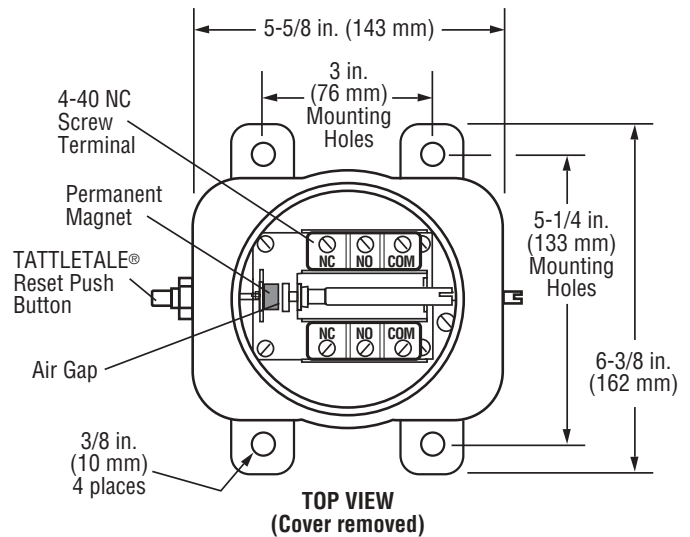

VS2EXR

- Remote Reset Feature
- NEMA 7 Specifications
- Snap-switch Contacts
- TATTLETALE® Reset Button

Model VS2EXR features an electric remote reset feature in addition to the TATTLETALE® reset button. The VS2EXR uses only one SPDT snap-switch and is CSA and UL listed for Class I, Division 1, Groups C & D hazardous locations. It is constructed to meet NEMA 7 specifications.

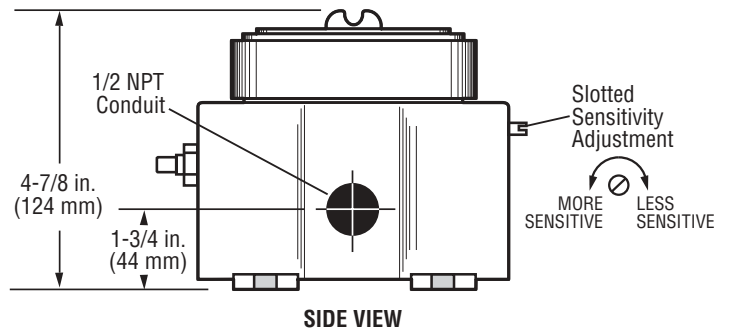
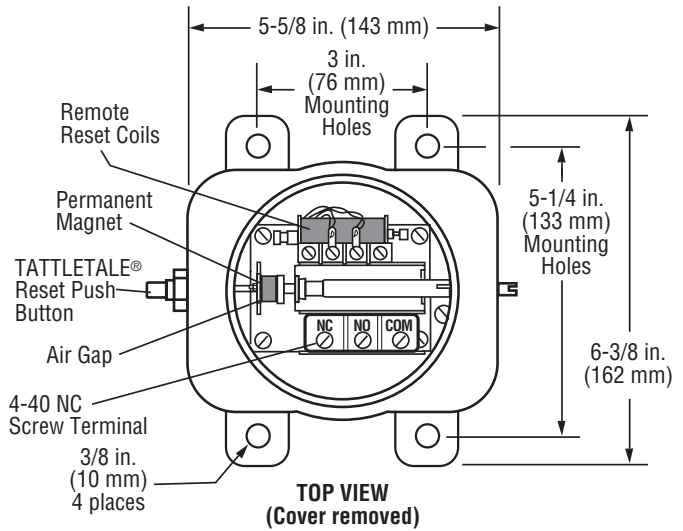

ELECTRICAL

Contact Rating:

- 5 A @ 125-480 VAC
- 1/2 A @ 125 VDC
- 1/4 A @ 250 VDC
- 2 A Resistive 30 VDC
- 1 A Inductive 30 VDC

Remote Reset Rating:

- 115 VAC or 24 VDC (Specify)
- 350 mA AC/DC

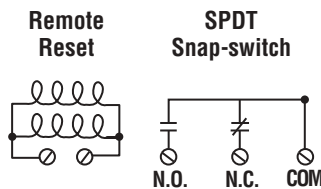

VS2EXRB

- For Group B Locations
- Snap-switch Contacts
- DPDT Feature Optional
- TATTLETALE® Reset Button

Model VS2EXRB is constructed for use in Class I, Division 1, Group B, hazardous locations. It has, as standard, a SPDT snap-switch and an electric remote reset. Option is available for DPDT snap-switch.

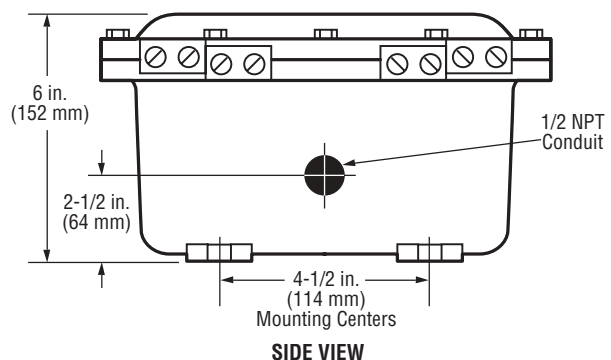
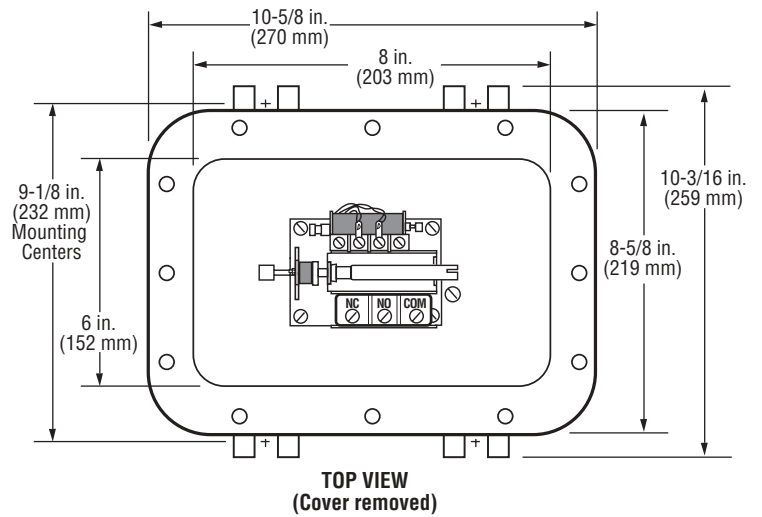

ELECTRICAL

Contact Rating:

- 5 A @ 125-480 VAC
- 1/2 A @ 125 VDC
- 1/4 A @ 250 VDC
- 2 A Resistive 30 VDC
- 1 A Inductive 30 VDC

Remote Reset Rating:

- 115 VAC or 24 VDC (Specify)
- 350 mA AC/DC

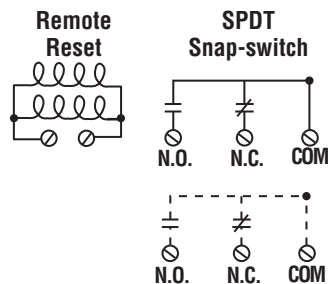

Option SPDT Snap-switch (DPDT)

How to Order

To order your VS2 Series model use the diagram below.
Part number example: **VS2EXR-24**

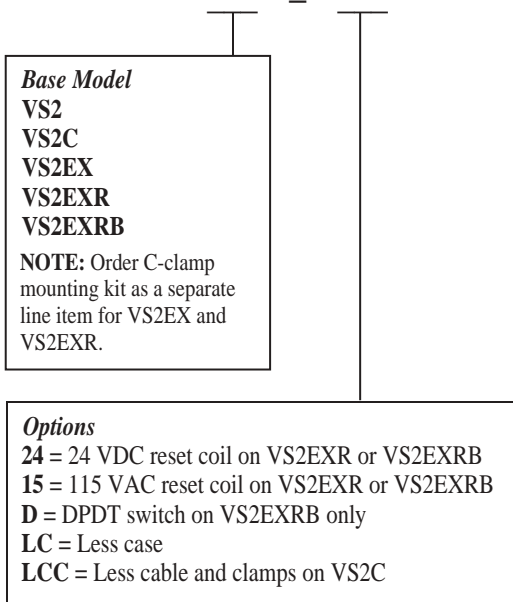

Shipping Information

VS2 and VS2C

Shipping Weight:

VS2: 2 lb 8 oz. (1.1 kg)
VS2C: 7 lb (3.2 kg)

Shipping Dimensions:

VS2: 8-1/4 x 9-1/4 x 5 in. (210 x 235 x 127 mm)
VS2C: 12 x 7 x 5-1/2 in. (305 x 178 x 140 mm)

VS2EX

Shipping Weight: 4 lb 8 oz. (2 kg)

Shipping Dimensions: 8-1/4 x 9-1/4 x 5 in. (210 x 235 x 127 mm)

VS2EXR

Shipping Weight: 5 lb 8 oz. (2.2 kg)

Shipping Dimensions: 8-1/4 x 9-1/4 x 5 in. (210 x 235 x 127 mm)

VS2EXRB

Shipping Weight: 17 lb 8 oz. (7.9 kg)

Shipping Dimensions: 12 x 12 x 10 in. (305 x 305 x 254 mm)



FWMurphy

P.O. Box 470248
Tulsa, Oklahoma 74147 USA
+1 918 317 4100
fax +1 918 317 4266
e-mail sales@fwmurphy.com
www.fwmurphy.com

CONTROL SYSTEMS & SERVICES DIVISION

P.O. Box 1819; Rosenberg, Texas 77471; USA
+1 281 633 4500 fax +1 281 633 4588
e-mail sales@fwmurphy.com

MURPHY DE MEXICO, S.A. DE C.V.

Bldv. Antonio Rocha Cordero 300, Fracción del Aguaje
San Luis Potosí, S.L.P.; México 78384
+52 444 8206264 fax +52 444 8206336
Villahermosa Office +52 993 3162117
e-mail ventas@murphymex.com.mx
www.murphymex.com.mx

Service Parts

When ordering service parts, specify both part number and description in listing below.

PART NO. DESCRIPTION

VS2 and VS2C

20-00-0030 Movement assembly
20-00-0031 Glass and gasket assembly
20-00-0032 Reset push button assembly
20-05-0021 Mounting clamp
20-00-0261 Cable clamp assembly (1 each)
20-05-0465 2-Conductor electrical cable, 45 feet (13.7 meters)
20-00-0137 5 clamps and 45 feet (13.7 meters) of cable

VS2EX

20-01-0091 Movement assembly
20-05-0087 Cover
00-00-0309 Cover gasket
20-01-0090 Snap-switch and insulator kit (1 switch per kit)
prior to September 1, 1995.*
20-00-0288 **Snap-switch and insulator kit (1 switch per kit) for models manufactured on September 1, 1995 or later.***
20-00-0289 C-clamp conversion mounting kit

VS2EXR

20-00-0262 Movement assembly
20-05-0087 Cover
00-00-0309 Cover gasket
20-01-0090 Snap-switch and insulator kit (1 switch per kit)
prior to September 1, 1995.*
20-00-0288 **Snap-switch and insulator kit (1 switch per kit) for models manufactured on September 1, 1995 or later.***
20-00-0049 Reset solenoid assembly (115 VAC)
20-00-0234 Reset solenoid assembly (24 VDC)
20-00-0289 C-clamp conversion mounting kit

VS2EXRB

20-01-0090 Snap-switch and insulator kit (1 switch per kit)
prior to September 1, 1995.*
20-00-0288 **Snap-switch and insulator kit (1 switch per kit) for models manufactured on September 1, 1995 or later.***
20-00-0057 *Inside* snap-switch and insulator kit (1 switch per kit) for model VS2EXRB-D **prior to September 1, 1995.***
20-00-0058 *Outside* snap-switch and insulator kit (1 switch per kit) for model VS2EXRB-D **prior to September 1, 1995.***
20-00-0287 **Inside** snap-switch and insulator kit (1 switch per kit) for model VS2EXRB-D **manufactured on September 1, 1995 or later.***
20-00-0290 **Outside** snap-switch and insulator kit (1 switch per kit) for model VS2EXRB-D **manufactured on September 1, 1995 or later.***
20-05-0077 Adjustment shaft
20-00-0262 Movement assembly
20-00-0049 Reset solenoid assembly (115 VAC)
20-00-0234 Reset solenoid assembly (24 VDC)

* Models with date 0895 and before use old switch. Dated 0995 after, use straight snap-switch arm, no rollers.

FRANK W. MURPHY, LTD.

Church Rd.; Laverstock, Salisbury SP1 1QZ; U.K.
+44 1722 410055 fax +44 1722 410088
e-mail sales@fwmurphy.co.uk
www.fwmurphy.co.uk

MURPHY SWITCH OF CALIFORNIA

41343 12th Street West
Palmdale, California 93551-1442; USA
+1 661 272 4700 fax +1 661 947 7570
e-mail sales@murphyswitch.com
www.murphyswitch.com

MACQUARRIE CORPORATION

1620 Hume Highway
Campbellfield, Vic 3061; Australia
+61 3 9358 5555 fax +61 3 9358 5558
e-mail murphy@macquarrie.com.au



In order to consistently bring you the highest quality, full featured products, we reserve the right to change our specifications and designs at any time.

Printed in U.S.A.